

YAMAHA

PARTS CATALOGUE

YZ125LC'90 (3SR1)

EUROPE

YZ125A (3SR2)

CANADA, OTHERS, S.AFRICA

YZ125 (3SR3)

JAPAN

YZ125A (3SR4)

OCEANIA

103SR-100E1



FOREWORD

This Parts Catalogue is related to the parts in use for the Yamaha YZ125LC'90(3SR1)/YZ125A(3SR2)/YZ125(3SR3)/YZ125A(3SR4). When you are ordering replacement parts for the YZ125LC'90(3SR1)/YZ125A(3SR2)/YZ125(3SR3)/YZ125A(3SR4), refer to this Parts Catalogue and quote both part numbers and part names correctly.

1. Modifications or additions which have been made after issue of the Parts Catalogue will be announced in the Yamaha Parts News.

It is advisable that according to the Yamaha Parts News you make necessary corrections to the Parts Catalogue on hand to keep it up-to-date.

2. Abbreviations

The following abbreviations are used in this Parts Catalogue.

- U.R. Use size (thickness) and/or number as required.
- U.N. Use as many as you need.
- A.P. Alternate Parts
- L.M. Local Made
- F# Frame No. (Applicable machine No.)

3. The parts marked with (*) in the parts number column of this Catalogue are not supplied with by Yamaha, those have to be found locally.
4. Parts, which are to be supplied in the form of assemblies, are listed with an indentation of one letter's space, and a dot (.) is put against the name of each part.

EXAMPLE CARBURETOR ASS'Y
 . JET, pilot
 . NOZZLE, main

5. Indication of No. of constituent parts for assembly

The numeral appearing to the right of each constituent part under the description indicates the quantity of such parts for each individual assembly unit.

EXAMPLE

Part No.	Description	Q'ty	Remarks
2F5-83310-60	FRONT FLASHER LIGHT ASS'Y	2	
115-83311-60	. BULB (6V-18W)	1	
1M1-83309-60	. REFLECTOR	1	

6. Initial Serial No. and Color Code

3SR1	(A) Frame Serial No.	3SR-000101 and following
	(B) Engine Serial No.	3SR-000101 and following

3SR2	(A) Frame Serial No.	3SR-006101 and following
	(B) Engine Serial No.	3SR-006101 and following

3SR3	(A) Frame Serial No.	3SR-015101 and following
	(B) Engine Serial No.	3SR

3SR4	(A) Frame Serial No.	3SR-016101 and following
	(B) Engine Serial No.	3SR-016101 and following

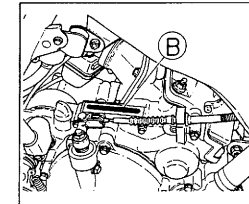
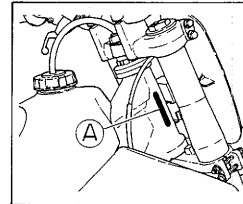

Color Code	Color Name	Abbreviate
36	CLEAN WHITE	W

7. Applicable colors of graphics are represented in the "Remarks" column by the letter(s) appropriately picked out of the full word(s) showing such colors.

EXAMPLE

Part No.	Description	Q'ty	Remarks
2N4-24110-00-X5	FUEL TANK COMP.	1	MAXIM RED
3J1-24240-10	. GRAPHIC, fuel tank set	1	for MXR

CONTENTS

ENGINE

Cylinder Head	B2 ~ B3
Governor	B4
Crankshaft. Piston	B5
Water Pump	B6
Radiator. Hose	B7
Intake	B8 ~ B9
Carburetor	B10 ~ B12
Exhaust	B13
Crankcase	B14
Crankcase Cover 1	B15
Starter	C2
Clutch	C3 ~ C4
Transmission	C5 ~ C6
Shift Cam. Fork	C7
Shift Shaft	C8

CHASSIS

Frame	C9 ~ C10
Fender	C11
Side Cover	C12 ~ C13
Rear Arm	C14 ~ C15
Rear Suspension	D2
Steering	D3
Front Fork	D4 ~ D6
Fuel Tank	D7
Seat	D8
Front Wheel	D9
Front Brake Caliper	D10
Rear Wheel	D11 ~ D12

Rear Brake Caliper	D13
Steering Handle. Cable	D14
Front Master Cylinder	D15
Stand. Footrest	E2
Rear Master Cylinder	E3
Generator	E4
Handle Switch. Lever	E5
Electrical 1	E6

ALTERNATE PARTS

Alternate 1 (Chassis)	E7
-----------------------------	----

REPAIR KIT

Repair Kit	E8
------------------	----

INDEX

Numerical Index	M1 ~ M3
-----------------------	---------

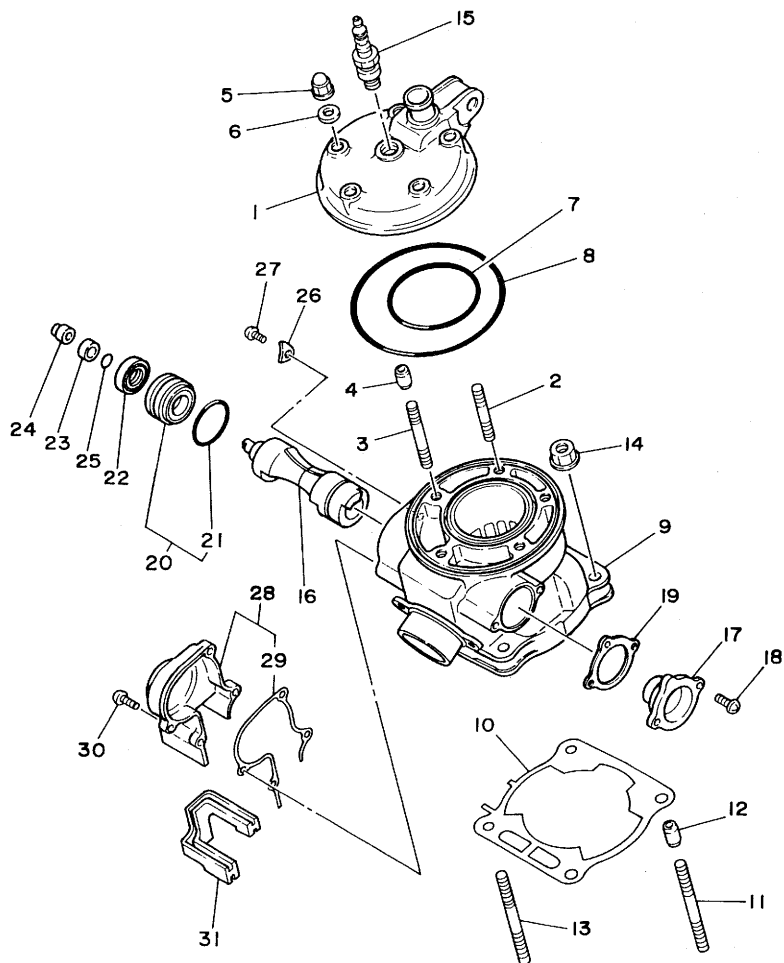

FIG. 1 CYLINDER HEAD

REF. NO.	PART NO.	DESCRIPTION	Q'TY	REMARKS
1	3SR-11111-00	HEAD, cylinder 1	1	
2	90116-08394	BOLT, stud	3	
3	90116-08392	BOLT, stud	2	
4	99510-10114	PIN, dowel	2	
5	90176-08026	NUT, crown	5	
6	90201-08087	WASHER, plate	5	
7	93210-65721	O-RING	1	
8	93211-07720	O-RING	1	
9	3SR-11311-00	CYLINDER 1	1	
10	1LX-11351-00	GASKET, cylinder	1	UR
	1LX-11351-10	GASKET, cylinder	1	UR FOR SWEDEN
11	90116-08388	BOLT, stud	2	
12	99510-10114	PIN, dowel	2	
13	90116-08533	BOLT, stud	2	
14	90179-08491	NUT	4	
15	94702-00325	PLUG, spark (NGK B9EG)	1	UR
	94702-00324	PLUG, spark (NGK BR9EG)	1	UR FOR CANADA, S.AFRICA
16	3SR-1131A-00	VALVE 1	1	
17	3JE-W1132-00	HOLDER 1	1	
18	98501-05012	SCREW, pan head	2	
19	5X4-1131N-00	GASKET, holder	1	UR
	5X4-1131N-10	GASKET, holder	1	UR FOR SWEDEN
20	2VN-Y113F-00	HOLDER 2 ASSY	1	
21	93210-27244	O-RING	1	
22	93104-16074	OIL SEAL	1	
23	90387-102W0	COLLAR	1	
24	3JE-11937-00	BOSS, lever	1	
25	93210-09192	O-RING	1	



3SR2100-0010

B2

FIG. 1 CYLINDER HEAD

REF. NO.	PART NO.	DESCRIPTION	Q'TY	REMARKS
26	47X-11915-00	PLATE, thrust 1	1	
27	98506-05008	SCREW, pan head	1	
28	3JD-11992-00	HOUSING 2	1	UR
	3JD-11992-10	HOUSING 2	1	UR FOR SWEDEN
29	3JD-11993-00	.GASKET	1	UR
	3JD-11993-10	.GASKET	1	UR FOR SWEDEN
30	98501-05016	SCREW, pan head	4	
31	1LX-11995-01	SEAL, housing	1	

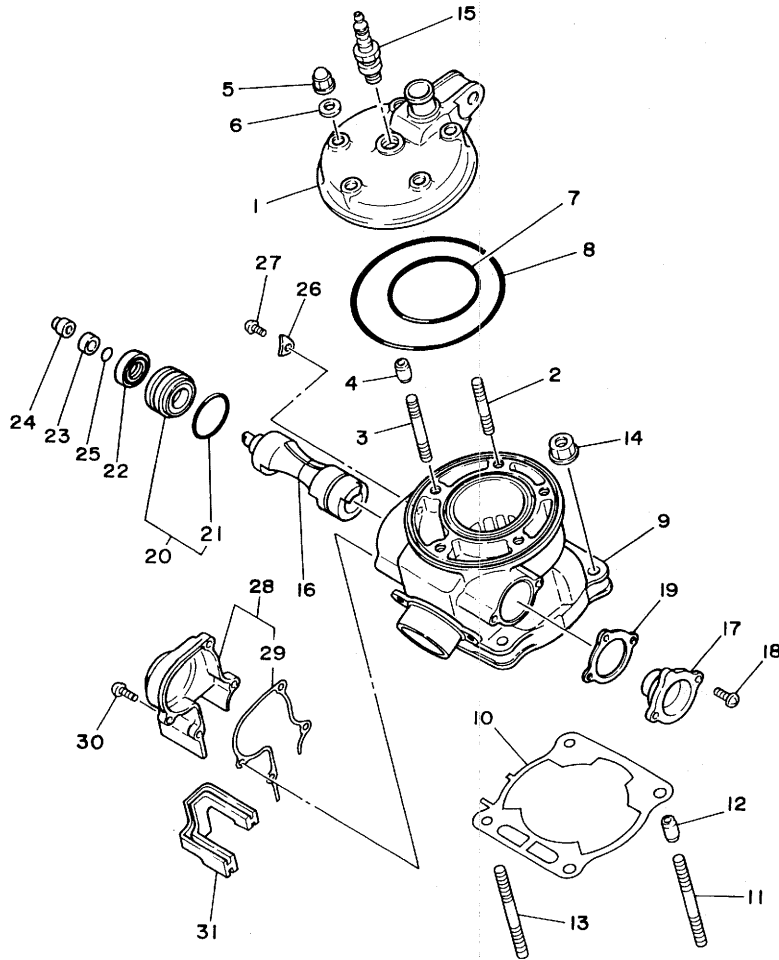

3SR2100-0010

B3

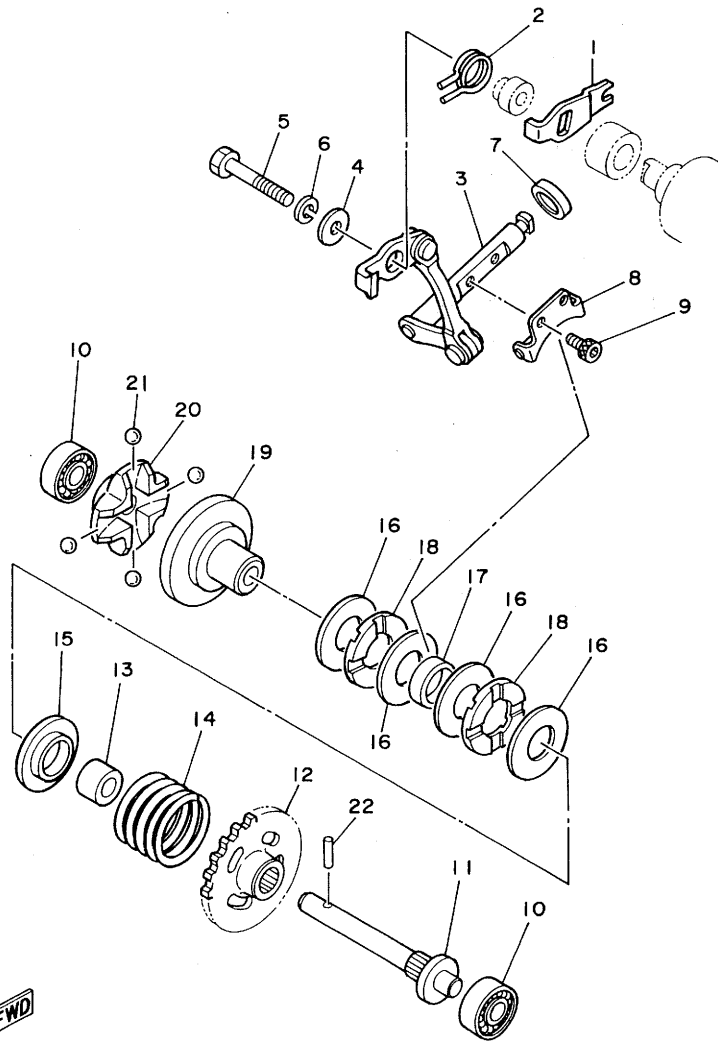

FIG. 2 GOVERNOR

REF. NO.	PART NO.	DESCRIPTION	Q'TY	REMARKS
1	3JE-11931-00	LEVER	1	
2	90508-14783	SPRING, torsion	1	
3	3SR-11990-00	PUSH ROD ASSY	1	
4	90201-057H5	WASHER, plate	1	
5	97021-05030	BOLT	1	
6	92990-05100	WASHER, spring	1	
7	93104-08040	OIL SEAL	1	
8	5X4-11922-00	FORK, governor	1	
9	91316-04006	BOLT	2	
10	93300-60814	BEARING (608M4ML01)	2	NMB
11	5X4-11921-02	SHAFT, governor	1	
12	3JD-11953-00	GEAR, governor	1	
13	90560-08213	SPACER	1	
14	90501-240E7	SPRING, compression	1	
15	5X4-11952-00	PLATE	1	
16	90201-154E9	WASHER, plate	4	
17	90387-152F2	COLLAR	1	
18	90380-15104	BUSH, solid	2	
19	5X5-11912-01	RETAINER, weight	1	
20	5X5-11911-01	RETAINER	1	
21	93521-64032	BALL	4	
22	93603-14179	PIN, dowel	1	

3SR2100-0020

B4

FIG. 3 CRANKSHAFT. PISTON

REF. NO.	PART NO.	DESCRIPTION	Q'TY	REMARKS
1	3SR-11400-00	CRANKSHAFT ASSY	1	
2	3SR-11412-00	.CRANK 1	1	
3	3SR-11422-00	.CRANK 2	1	
4	2HG-11651-00	.ROD, connecting	1	
5	3JD-11681-00	.PIN, crank 1	1	
6	90209-22257	.WASHER	2	
7	93310-522B9	.BEARING, cylindrical	1	
8	3SR-11631-00-94	PISTON (STD)	1	UR
	3SR-11631-00-95	PISTON (STD)	1	UR
9	5X4-11611-00	RING, piston (STD)	1	
10	137-11633-00	PIN, piston	1	
11	93450-17129	CIRCLIP	2	
12	93310-216L2	BEARING, cylindrical	1	
13	93306-37204	BEARING (63/22SH2-9TC4)	2	KOYO
14	93102-22363	OIL SEAL	1	
15	93103-32099	OIL SEAL	1	
16	90280-03045	KEY, woodruff	1	
17	90282-05038	KEY, straight	1	

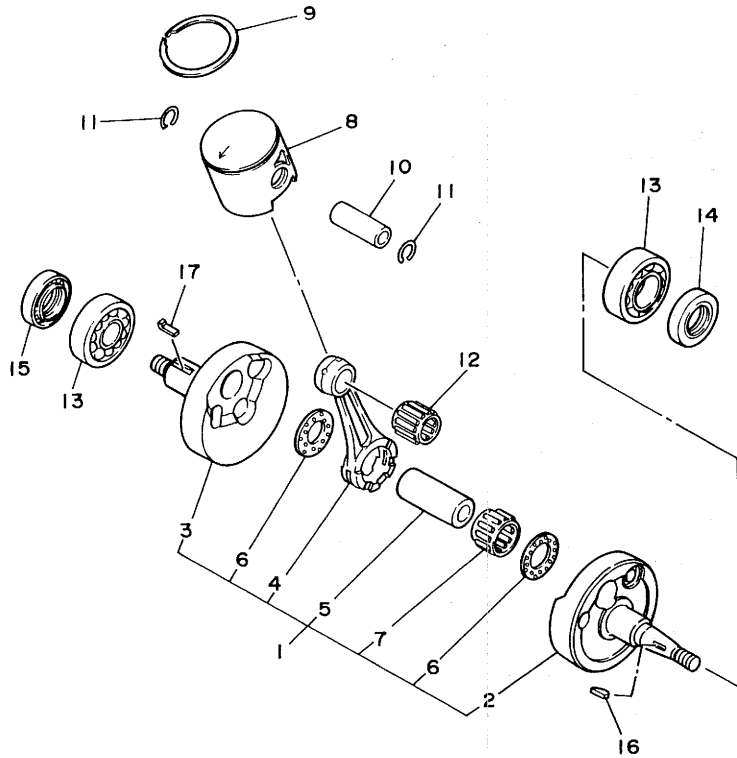

3SR2100-0030

B5

FIG. 5 RADIATOR. HOSE

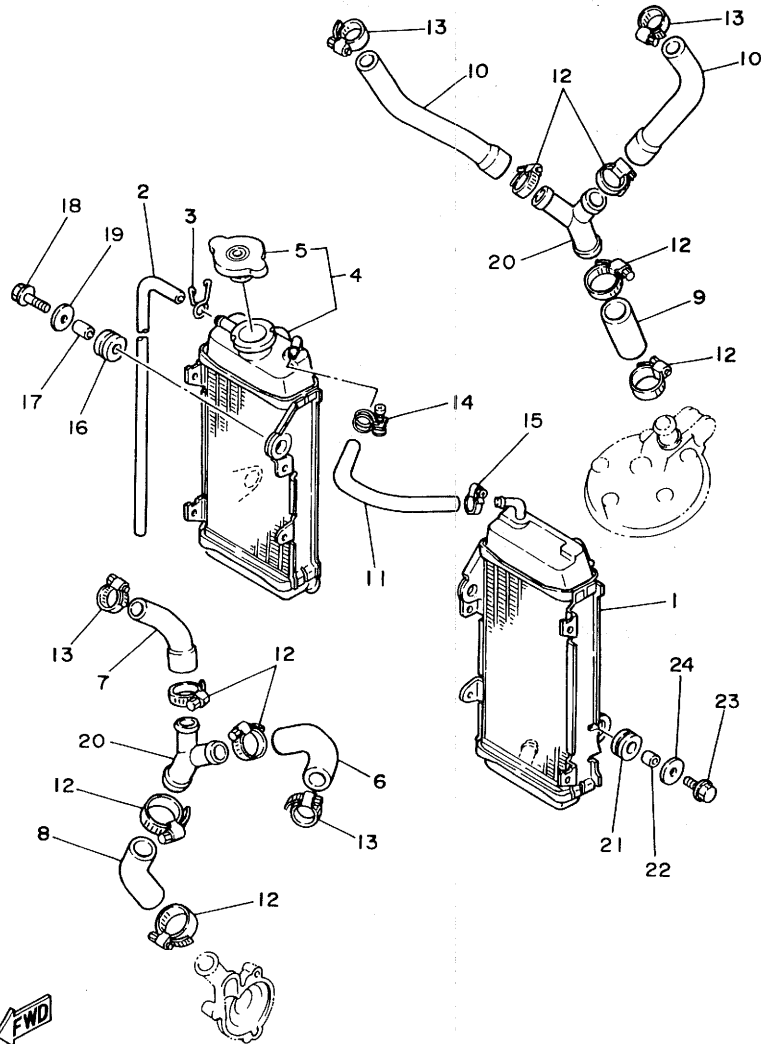

3SR2100-0050

REF. NO.	PART NO.	DESCRIPTION	Q'TY	REMARKS
1	3JD-1240A-00	RADIATOR ASSY 2	1	
2	90446-09013	HOSE	1	
3	90467-09006	CLIP	1	
4	1LX-1240A-00	RADIATOR ASSY 2	1	
5	22W-12462-00	.CAP, radiator	1	
6	3JD-12481-01 37D 12182-00	PIPE 1	1	
7	3JD-12481-00 3	PIPE 2	1	
8	3JD-12487-00 1-01	PIPE 3	1	
9	3JD-12485-00	PIPE 5	1	
10	3JD-12476-00	PIPE 6	2	
11	1LU-1248A-01	PIPE 8	1	
12	90450-28014	HOSE CLAMP ASSY	8	
13	90450-22017	HOSE CLAMP ASSY	4	
14	90450-15041	HOSE CLAMP ASSY	1	
15	90450-17036	HOSE CLAMP ASSY	1	
16	90480-15064	GROMMET	2	
17	90387-07392	COLLAR	2	
18	95023-06030	BOLT	2	
19	90201-06570	WASHER, plate	2	
20	24X-12469-00	JOINT 1	2	
21	90480-18276	GROMMET	2	
22	90387-07573	COLLAR	2	
23	95023-06020	BOLT	2	
24	90201-06570	WASHER, plate	2	

B7

FIG. 6 INTAKE

REF. NO.	PART NO.	DESCRIPTION	Q'TY	REMARKS
1	2VN-13610-00	REED VALVE ASSY	1	
2	1RX-13613-00	.REED, valve	2	
3	2VN-13616-00	.STOPPER, reed valve	2	
4	98501-03008	.SCREW, pan head	6	
5	92990-03100	.WASHER, spring	6	
6	80L-13621-01	GASKET, valve seat	1	UR
	2K7-13621-10	GASKET, valve seat	1	UR FOR SWEDEN
7	3SR-13565-00	JOINT, carburetor	1	
8	95023-06020	BOLT	4	
9	90460-51109	CLAMP, hose	1	
10	90460-68230	CLAMP, hose	1	
11	3JD-14453-00	JOINT, air cleaner 1	1	
12	3JD-14459-00	HOLDER, guide	1	
13	3JD-14462-00	SEAL	1	
14	39K-14457-00	SEAL	1	
15	90504-03033	SPRING, compression	1	
16	3SP-W1441-00	AIR CLEANER CASE COMP.	1	
17	3JD-14477-00	PLATE	1	
18	95601-05100	NUT, u	5	
19	3JD-14451-00	ELEMENT, air cleaner	1	
20	3JD-14458-00	GUIDE	1	
21	90209-06096	WASHER	1	
22	90122-06030	BOLT, wing	1	
23	92990-06100	WASHER, spring	1	
24	3SP-14461-00	ELEMENT, air cleaner 2	1	
25	90269-11042	RIVET	1	
26	90201-08085	WASHER, plate	1	
27	95023-06012	BOLT	2	

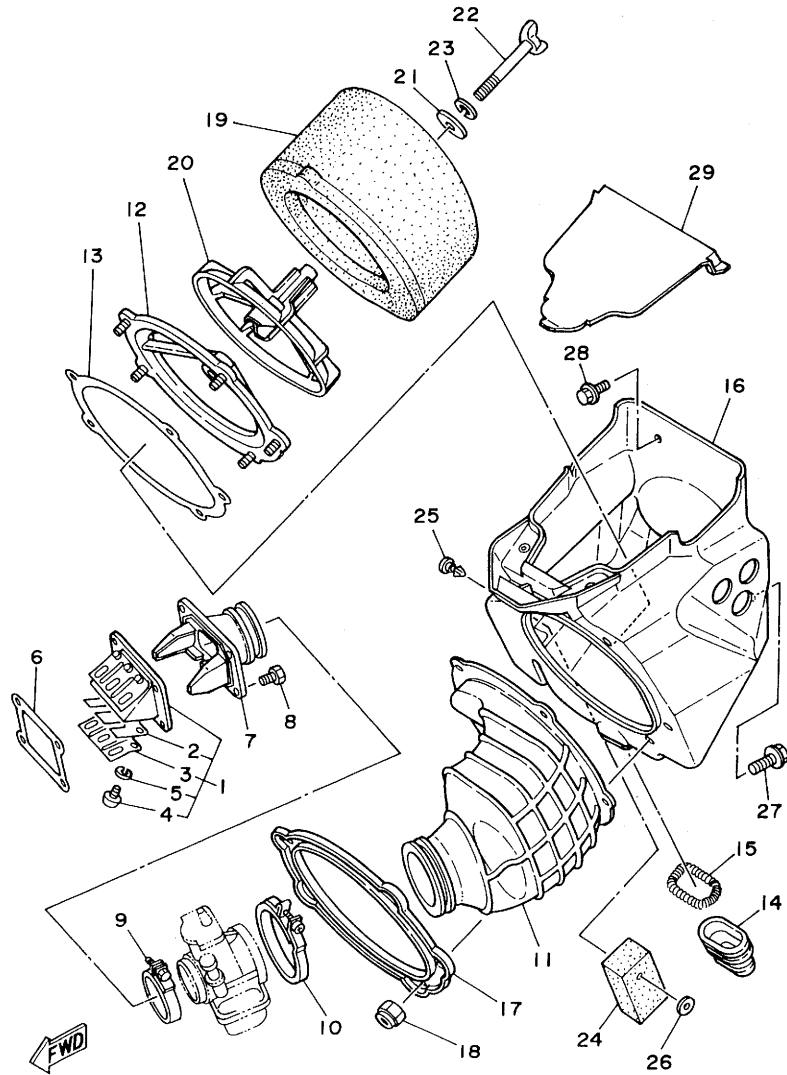

3SR2100-0060

FIG. 6 INTAKE

REF. NO.	PART NO.	DESCRIPTION	Q'TY	REMARKS
28	90119-06185	BOLT, with washer	1	
29	3SP-1441A-00	COVER, cleaner case 1	1	AP

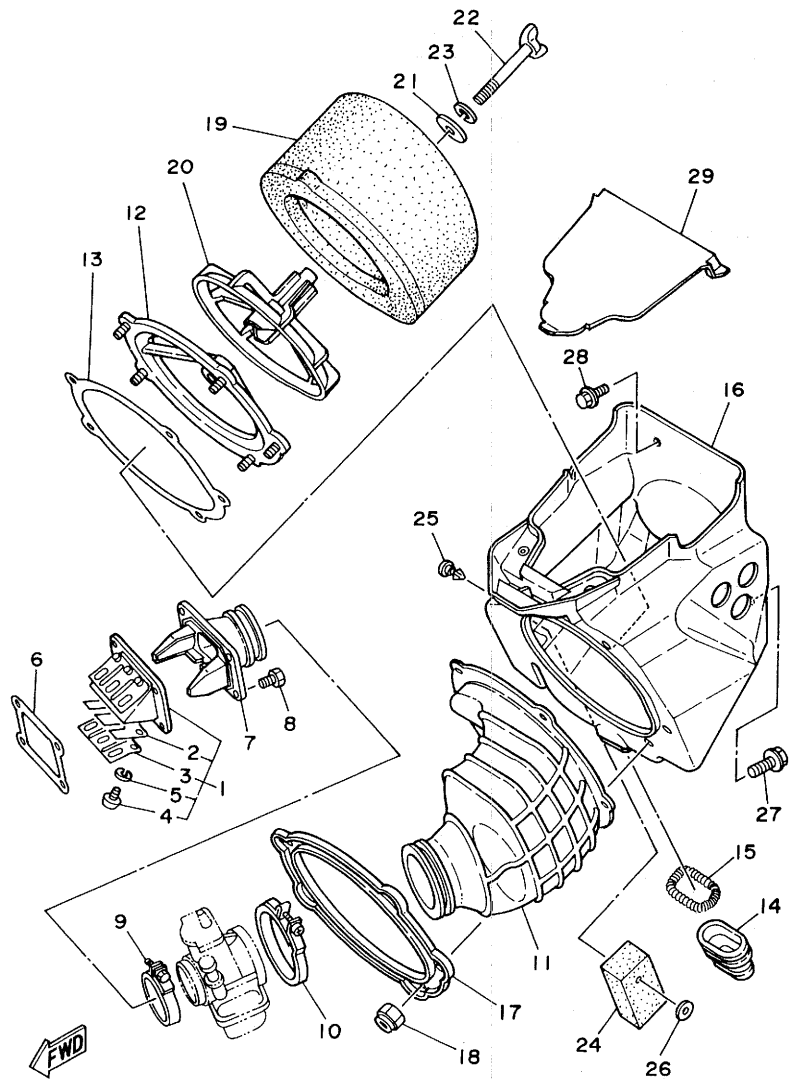

3SR2100-0060

B9

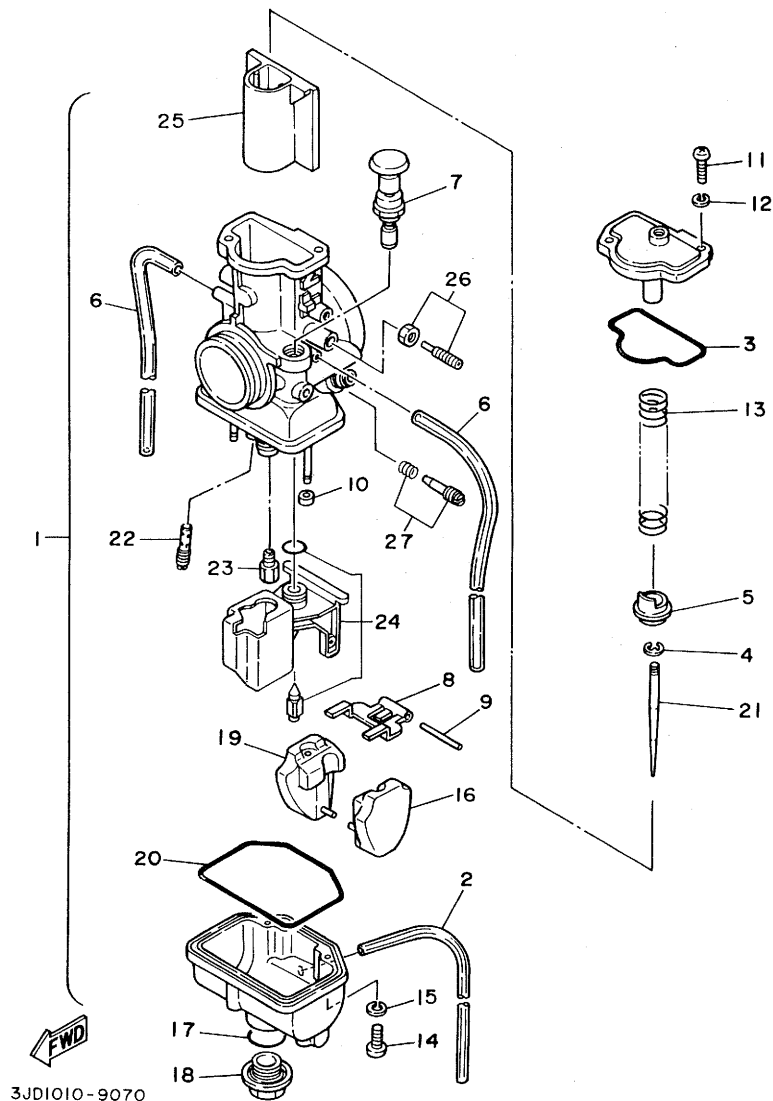

3JD1010-9070

FIG. 7 CARBURETOR

REF. NO.	PART NO.	DESCRIPTION	Q'TY	REMARKS
1	3SR-14101-00	CARBURETOR ASSY 1	1	UR { FOR U.S.A., CANADA, OCEANIA, S.AFRICA, OTHERS
	3SR-14101-10	CARBURETOR ASSY 1	1	UR FOR EUROPE
	3SR-14101-20	CARBURETOR ASSY 1	1	UR FOR JAPAN
2	278-14197-00	.PIPE	1	
3	3JD-14147-00	.O-RING	1	
4	256-14919-00	.CLIP	1	
5	3JD-14194-00	.RING	1	
6	2HH-14197-00	.PIPE	2	
7	3JE-14171-00	.PLUNGER, starter	1	
8	363-14187-00	.ARM, float	1	
9	353-14186-00	.PIN, float	1	
10	214-14118-00	.CAP	2	
11	98511-04012	.SCREW, pan head	2	
12	92902-04100	.WASHER, spring	2	
13	3JD-14131-00	.SPRING, throttle valve	1	
14	98501-03008	.SCREW, pan head	1	
15	92990-03100	.WASHER, spring	1	
16	3JD-14185-00	.FLOAT	1	
17	3JE-14561-00	.O-RING	1	
18	3JD-14115-00	.PLUG, screw	1	
19	3JE-14185-00	.FLOAT	1	
20	3JE-14147-00	.O-RING	1	
21	3JD-14116-A2	.NEEDLE (J8-6EN15-53)	1	AP
	3JD-14116-A3	.NEEDLE (J8-6EN15-54)	1	AP
	3JD-14116-A1	.NEEDLE (J8-6EN15-55)	1	AP STD FOR EUROPE
	3JD-14116-A4	.NEEDLE (J8-6EN15-56)	1	AP STD { FOR U.S.A., CANADA, OCEANIA, OTHERS, JAPAN
	3JD-14116-A5	.NEEDLE (J8-6EN15-57)	1	AP
22	193-14142-20	.JET, pilot (# 20)	1	UR STD

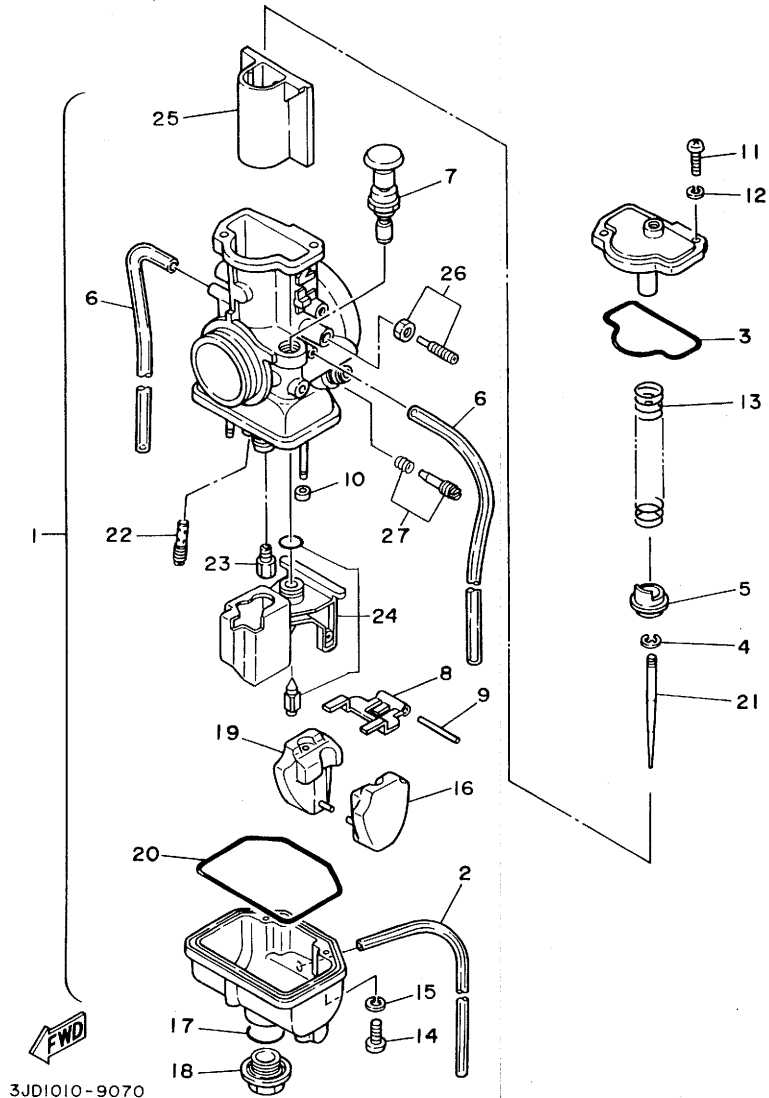

3JD1010-9070

FIG. 7 CARBURETOR

REF. NO.	PART NO.	DESCRIPTION	Q'TY	REMARKS
22	193-14142-17	.JET, pilot (#17.5)	1	AP
	193-14142-25-A0	.JET, pilot (# 25)	1	AP
22	193-14142-30-A0	.JET, pilot (# 30)	1	AP
23	137-14143-50-A0	.JET, main (#250)	1	AP
	137-14143-52	.JET, main (#260)	1	AP
	137-14143-54	.JET, main (#270)	1	AP STD FOR JAPAN
	137-14143-56-A0	.JET, main (#280)	1	AP
	137-14143-58-A1	.JET, main (#290)	1	AP
	137-14143-60-A0	.JET, main (#300)	1	AP
	137-14143-62	.JET, main (#310)	1	AP STD {FOR U.S.A., CANADA, OCEANIA, EUROPE, S.AFRICA, OTHERS
	137-14143-64	.JET, main (#320)	1	AP
	137-14143-66	.JET, main (#330)	1	AP
24	3JD-14107-35	.NEEDLE VALVE SET	1	
25	3JD-14112-45	.VALVE, throttle (C.A 4.5)	1	AP
	3JD-14112-50	.VALVE, throttle (C.A 5.0)	1	AP
	3JD-14112-55	.VALVE, throttle (C.A 5.5)	1	AP STD FOR EUROPE, JAPAN
	3JD-14112-60	.VALVE, throttle (C.A 6.0)	1	AP STD {FOR U.S.A., CANADA, OCEANIA, S.AFRICA, OTHERS

B11

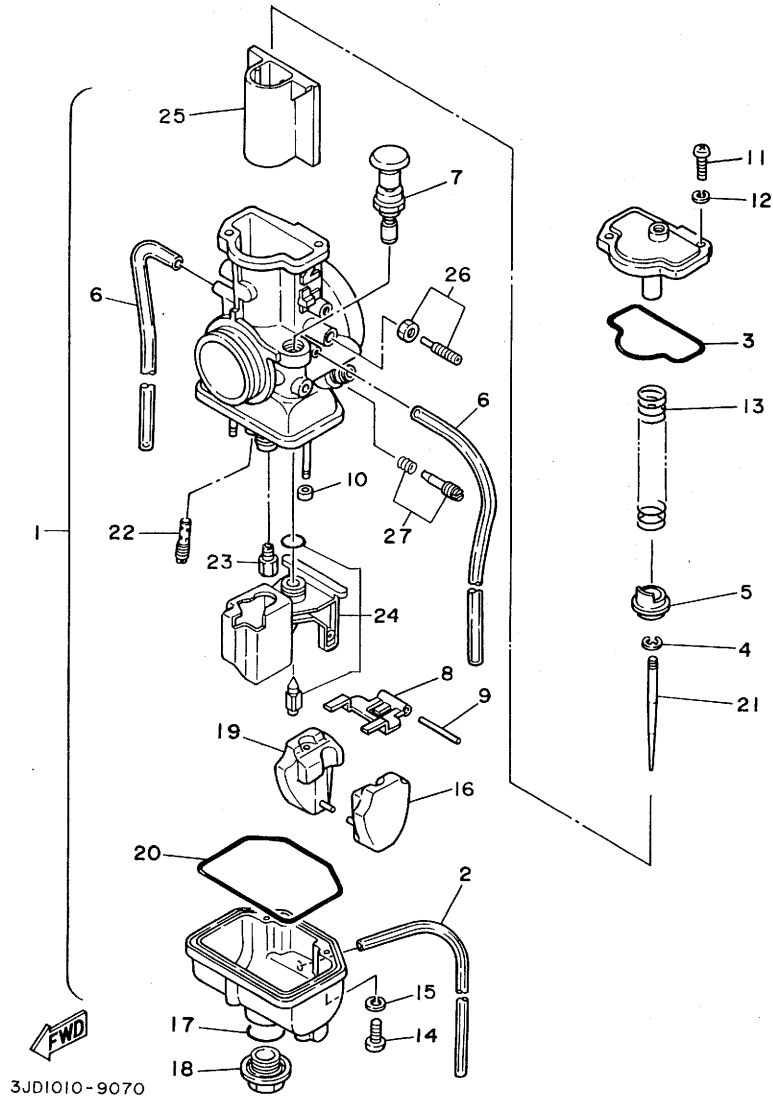
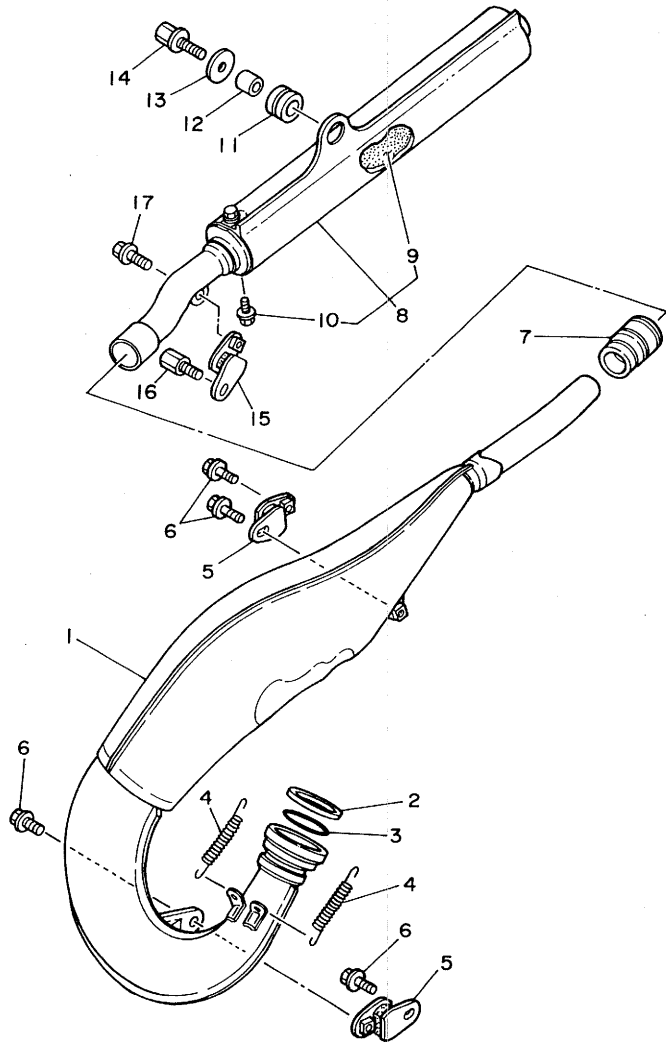

FIG. 7 CARBURETOR

REF. NO.	PART NO.	DESCRIPTION	Q'TY	REMARKS
26	3JD-14103-00	.THROTTLE SCREW SET	1	
27	3JD-14104-00	.AIR SCREW SET	1	

FIG. 8 EXHAUST



REF. NO.	PART NO.	DESCRIPTION	Q'TY	REMARKS
1	3SR-14610-00	EXHAUST PIPE ASSY 1	1	
2	3R3-14613-00	GASKET, exhaust pipe	1	
3	93210-45742	O-RING	1	
4	90507-20030	SPRING, tension	2	
5	565-14771-00	STAY, muffler 1	2	
6	95023-06012	BOLT	4	
7	3M7-14615-00	JOINT, exhaust 1	1	
8	3JD-14753-01	SILENCER, exhaust	1	
9	3JD-1469A-01	.FIBER	1	
10	95023-06008	.BOLT	2	
11	39X-14747-00	DAMPER, muffler	1	
12	90387-081A3	COLLAR	1	
13	90201-08612	WASHER, plate	1	
14	90109-08512	BOLT	1	
15	565-14771-00	STAY, muffler 1	1	
16	90109-06551	BOLT	1	
17	95023-06012	BOLT	1	

3SR2100-0080

B13

FIG. 9 CRANKCASE

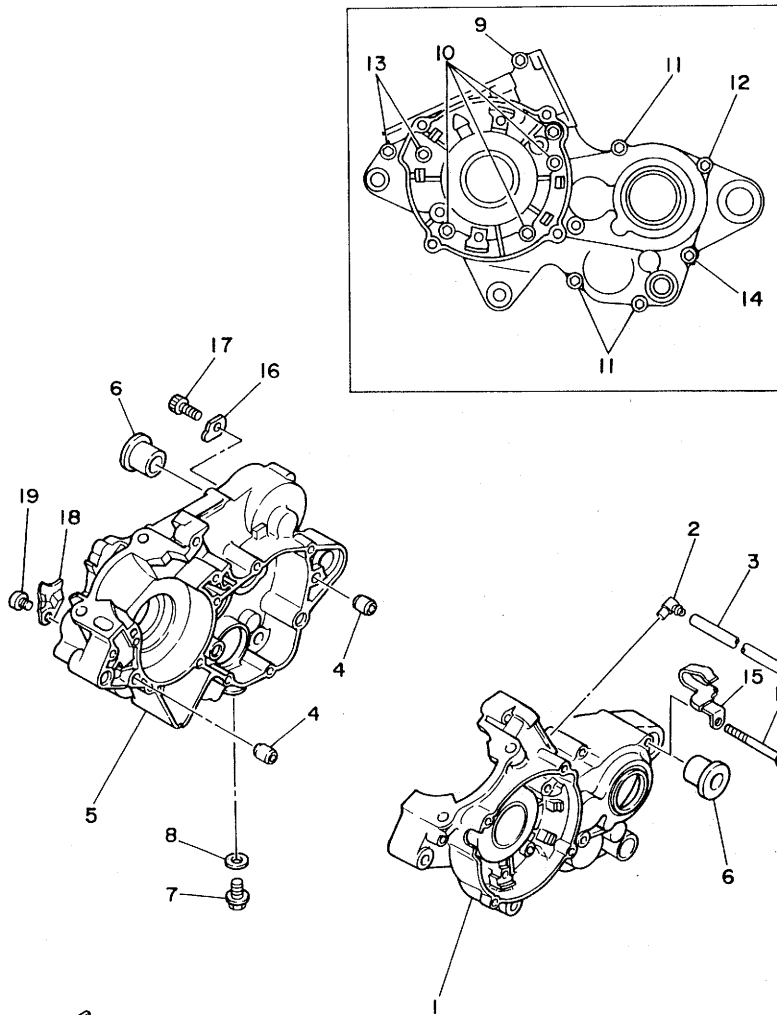

REF. NO.	PART NO.	DESCRIPTION	Q'TY	REMARKS
1	1LX-15111-12	CRANKCASE 1	1	
2	353-13115-01	CONNECTOR, suction pipe	1	
3	90445-08376	HOSE	1	
4	99510-12016	PIN, dowel	2	
5	1LX-15121-11	CRANKCASE 2	1	
6	90387-16781	COLLAR	2	
7	90340-12059	PLUG, straight screw	1	
8	90430-12038	GASKET	1	UR
	90430-12207	GASKET	1	UR FOR SWEDEN
9	91316-06035	BOLT	1	
10	91316-06045	BOLT	4	
11	91316-06055	BOLT	3	
12	91316-06070	BOLT	1	
13	91316-06060	BOLT	2	
14	91316-06065	BOLT	1	
15	90465-08336	CLAMP	1	
16	90209-06290	WASHER	1	
17	91316-05012	BOLT	1	
18	3R3-15128-01	HOLDER	1	
19	92501-08010	SCREW, pan head	1	



3JD1010-9090

B14

FIG. 10 CRANKCASE COVER 1

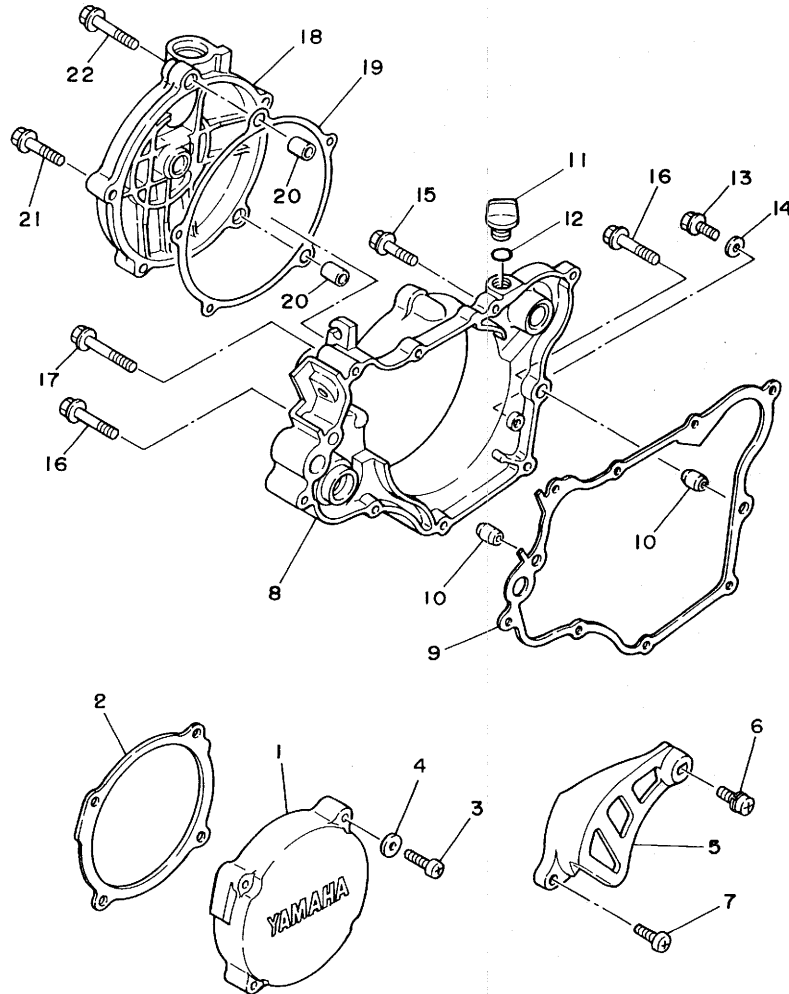

REF. NO.	PART NO.	DESCRIPTION	Q'TY	REMARKS
1	2VN-15411-00	COVER, crankcase 1	1	
2	1LX-15451-01	GASKET, crankcase cover 1	1	UR
	1LX-15451-11	GASKET, crankcase cover 1	1	UR FOR SWEDEN
3	92501-06035	SCREW, pan head	4	
4	92901-06600	WASHER, plate	4	
5	3SR-15421-00	COVER, crankcase 2	1	
6	90159-06146	SCREW, with washer	1	
7	92501-06014	SCREW, pan head	1	
8	3JD-15431-00	COVER, crankcase 3	1	
9	1LX-15462-00	GASKET, crankcase cover 3	1	UR
	1LX-15462-10	GASKET, crankcase cover 3	1	UR FOR SWEDEN
10	99530-10014	PIN, dowel	2	
11	1G8-15362-00	PLUG, oil level	1	
12	93210-14104	O-RING	1	
13	95023-06008	BOLT	1	
14	90430-06016	GASKET	1	
15	95023-06025	BOLT	6	
16	95023-06035	BOLT	2	
17	95023-06040	BOLT	1	
18	3JD-15415-01	COVER, generator	1	
19	3JD-15463-00	GASKET, crankcase cover 2	1	UR
	3JD-15463-10	GASKET, crankcase cover 2	1	UR FOR SWEDEN
20	99530-10014	PIN, dowel	2	
21	95023-06030	BOLT	3	
22	95023-06040	BOLT	2	

3SR2100-0100

B15

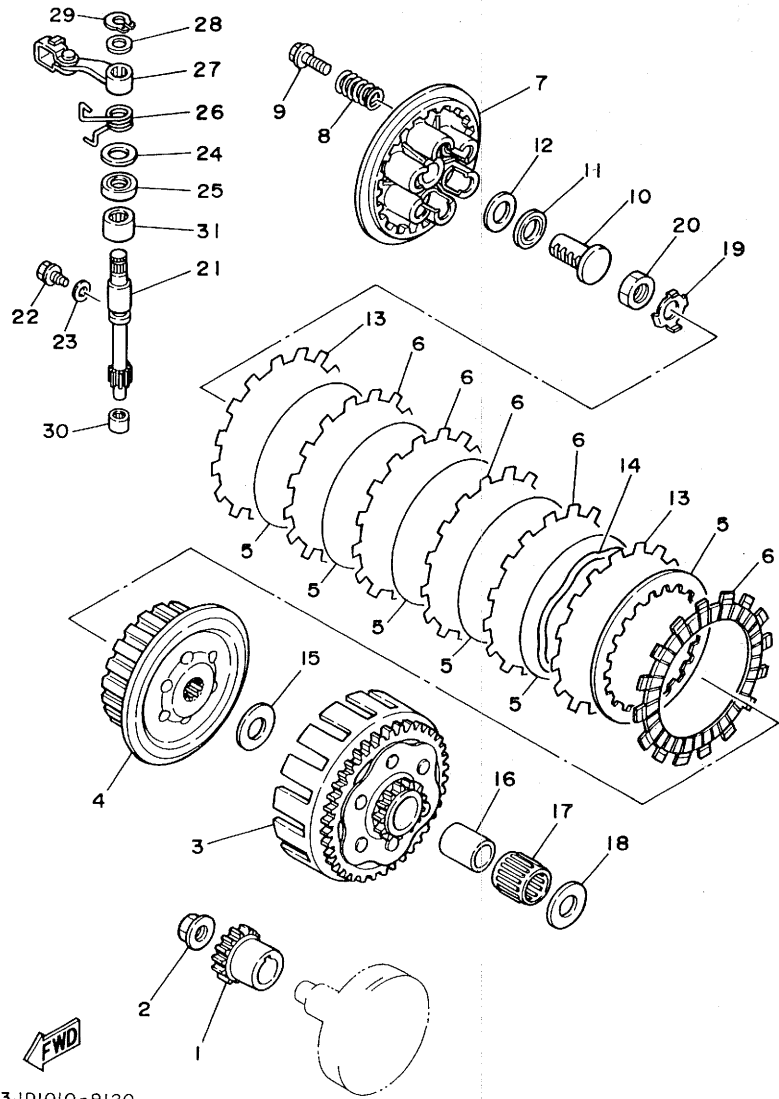

3JD1010-9120

FIG. 12 CLUTCH

REF. NO.	PART NO.	DESCRIPTION	Q'TY	REMARKS
1	3SR-16111-00	GEAR, primary drive	1	
2	90179-12373	NUT	1	
3	3JD-16150-00	PRIMARY DRIVEN GEAR COMP.	1	
4	3JD-16371-00	BOSS, clutch	1	
5	24X-16324-00	PLATE, clutch 1	6	
6	3JD-16321-00	PLATE, friction	5	
7	3JD-16351-00	PLATE, pressure 1	1	
8	90501-210F3	SPRING, compression	6	
9	90159-06016	SCREW, with washer	6	
10	4H7-16356-01	ROD, push 1	1	
11	93340-21505	BEARING	1	
12	90201-150H2	WASHER, plate	1	
13	3JD-16331-00	PLATE, friction 2	2	
14	3JD-16383-00	SPRING, clutch boss	1	
15	90201-174F7	WASHER, plate	1	
16	90560-17335	SPACER	1	
17	93310-323T6	BEARING, cylindrical	1	
18	90201-174E1	WASHER, plate	1	
19	90215-14224	WASHER, lock	1	
20	90170-14171	NUT	1	
21	3JD-16382-00	AXLE, push lever	1	
22	90109-06418	BOLT	1	
23	90430-06014	GASKET	1	
24	90201-12474	WASHER, plate	1	
25	93102-15212	OIL SEAL	1	
26	90508-14767	SPRING, torsion	1	
27	3JD-16340-00	PUSH LEVER ASSY	1	
28	90201-10119	WASHER, plate	1	

C3

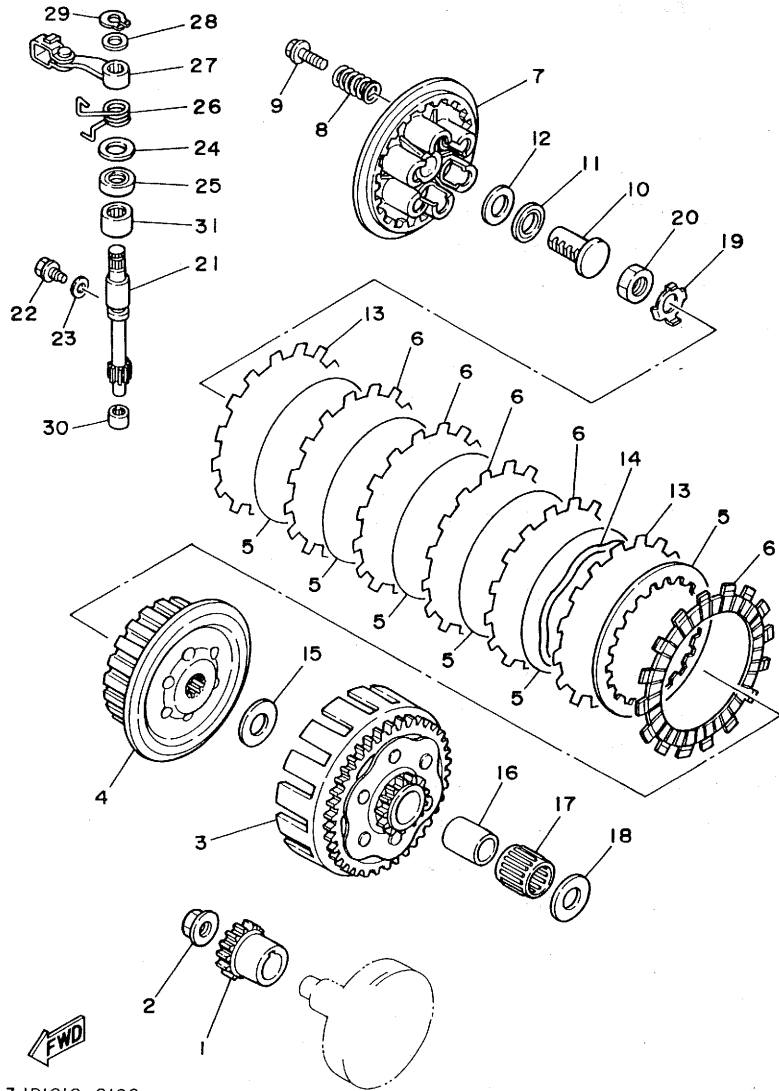

3JD1010-9120

FIG. 12 CLUTCH

REF. NO.	PART NO.	DESCRIPTION	Q'TY	REMARKS
29	99009-10400	CIRCLIP	1	
30	93315-10838	BEARING, cylindrical	1	
31	93315-31502	BEARING, cylindrical	1	

FIG. 13 TRANSMISSION

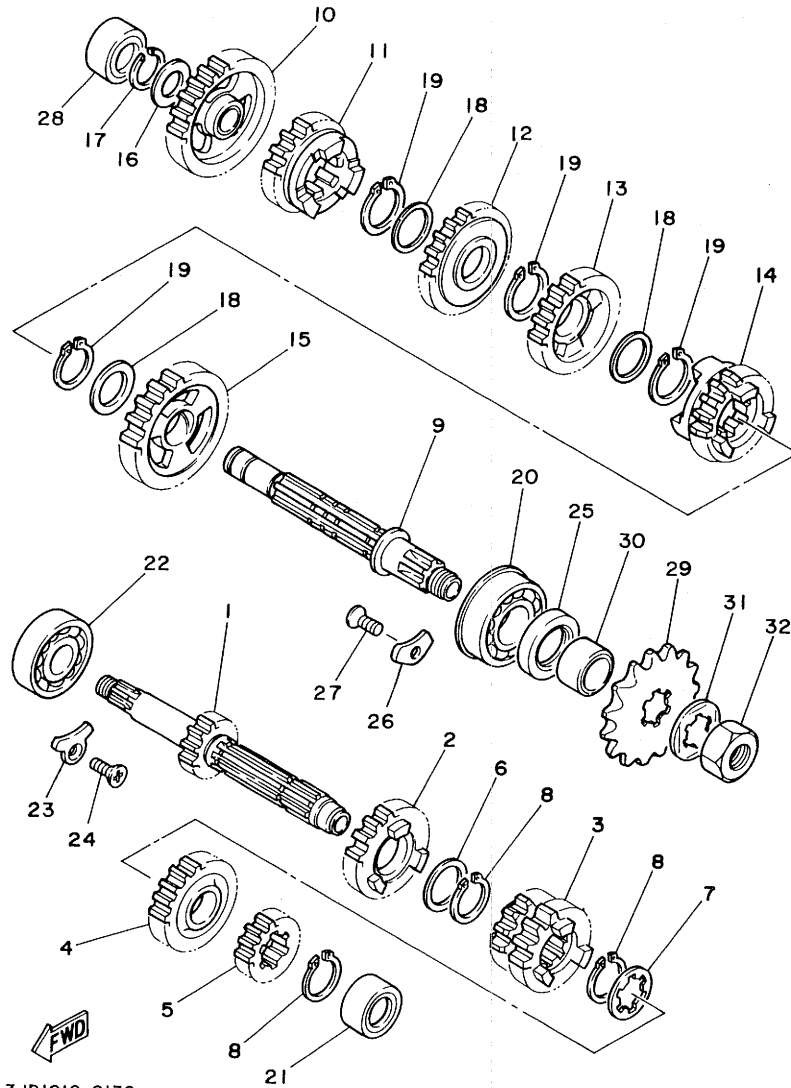

3JD1010-9130

REF. NO.	PART NO.	DESCRIPTION	Q'TY	REMARKS
1	3JD-17411-00	AXLE, main (13T)	1	
2	3JD-17151-00	GEAR, 5th pinion (20T)	1	
3	3SR-17131-00	GEAR, 3rd pinion	1	
4	3JD-17161-00	GEAR, 6th pinion (21T)	1	
5	3SR-17121-00	GEAR, 2nd pinion	1	
6	90201-22555	WASHER, plate	1	
7	90209-18135	WASHER	1	
8	93410-22039	CIRCLIP	3	
9	3JD-17421-00	AXLE, drive	1	
10	1LX-17211-00	GEAR, 1st wheel (30T)	1	
11	3JD-17251-00	GEAR, 5th wheel (23T)	1	
12	3SR-17231-00	GEAR, 3rd wheel	1	
13	1LX-17241-00	GEAR, 4th wheel (22T)	1	
14	3JD-17261-00	GEAR, 6th wheel (22T)	1	
15	3SR-17221-00	GEAR, 2nd wheel	1	
16	90201-15701	WASHER, plate (1.0T)	1	
17	93440-15012	CIRCLIP	1	
18	90201-22555	WASHER, plate	3	
19	93410-22039	CIRCLIP	4	
20	93306-30411	BEARING (B6304)	1	
21	93311-41530	BEARING, cylindrical	1	
22	93306-30309	BEARING (B6303ZZ)	1	
23	1LX-15383-00	PLATE, bearing cover	1	
24	92701-06012	SCREW, flat head	1	
25	93102-26042	OIL SEAL	1	
26	2K7-15383-00	PLATE, bearing cover	1	
27	92701-06012	SCREW, flat head	1	
28	93311-31567	BEARING, cylindrical	1	

C5

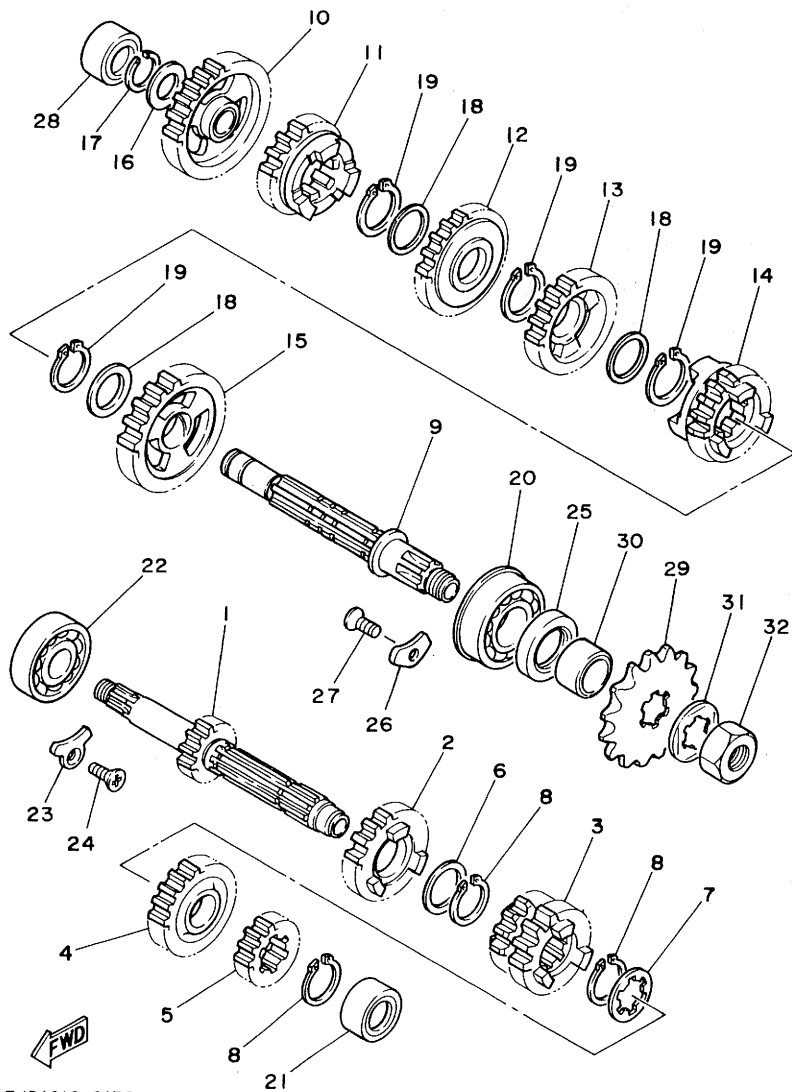

3JD1010-9130

FIG. 13 TRANSMISSION

REF. NO.	PART NO.	DESCRIPTION	Q'TY	REMARKS
29	9383A-13031	SPROCKET, drive 13T (2HG1746130)	1	STD
	9383A-12017	SPROCKET, drive 12T (2HG1746120)	1	AP
	9383A-14054	SPROCKET, drive 14T (2HG1746140)	1	AP
30	90387-202A0	COLLAR	1	
31	90215-20261	WASHER, lock	1	
32	90179-16226	NUT	1	

FIG. 14 SHIFT CAM. FORK

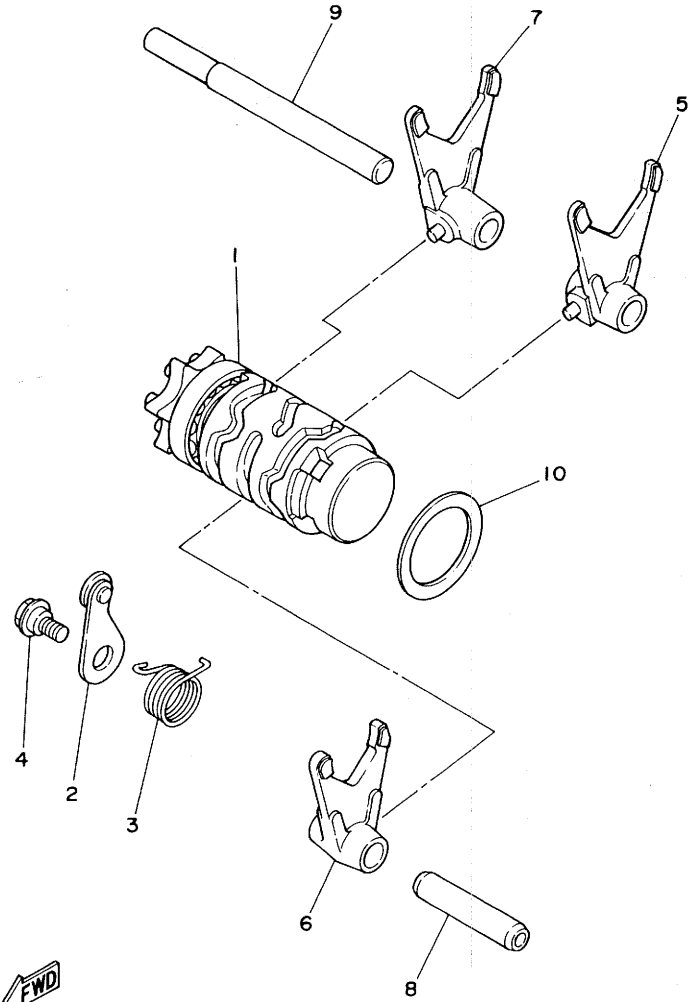

REF. NO.	PART NO.	DESCRIPTION	Q'TY	REMARKS
1	1LX-18540-00	SHIFT CAM ASSY	1	
2	3R4-18140-00	STOPPER LEVER ASSY	1	
3	90508-26731	SPRING, torsion	1	
4	90109-063F7	BOLT	1	
5	3JD-18511-01	FORK, shift 1	1	
6	2VN-18512-01	FORK, shift 2	1	
7	1LX-18513-01	FORK, shift 3	1	
8	1LX-18531-00	BAR, shift fork guide 1	1	
9	1LX-18535-00	BAR, shift fork guide 2	1	
10	90201-34683	WASHER, plate	1	

3JD1010-9140

C7

FIG. 15 SHIFT SHAFT

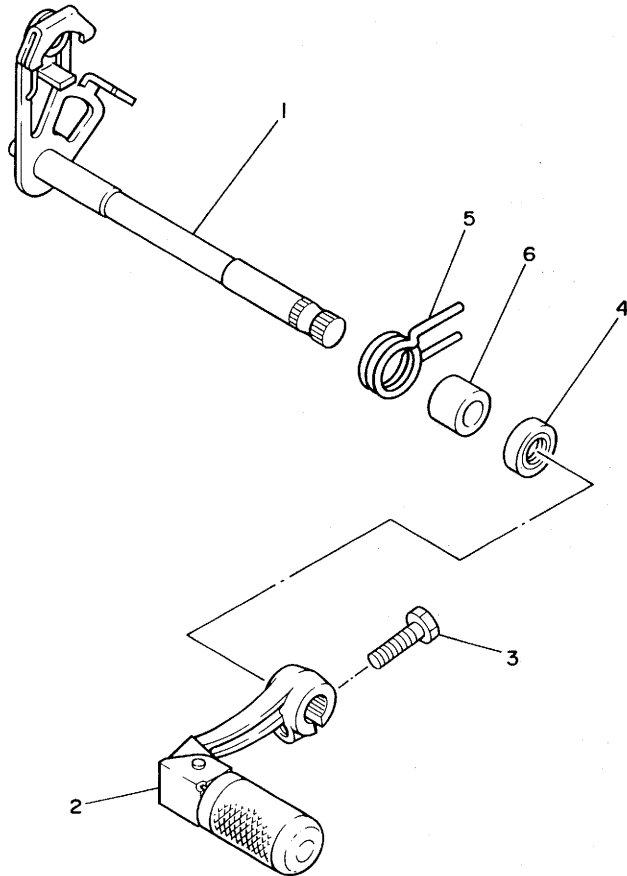

REF. NO.	PART NO.	DESCRIPTION	Q'TY	REMARKS
1	1LX-18101-02	SHIFT SHAFT ASSY	1	
2	1LX-18110-01	SHIFT PEDAL ASSY	1	
3	97021-06025	BOLT	1	
4	93109-12012	OIL SEAL	1	
5	90508-32535	SPRING, torsion	1	
6	90560-12280	SPACER	1	



ILX010-6150

C8

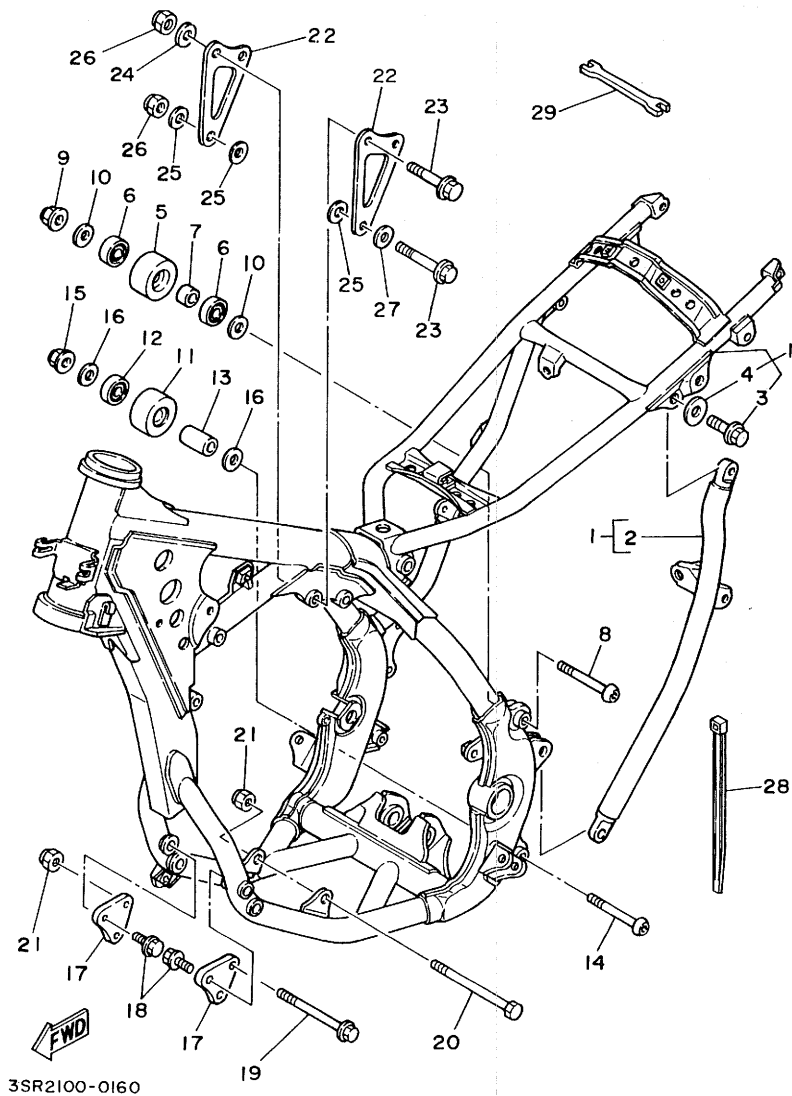
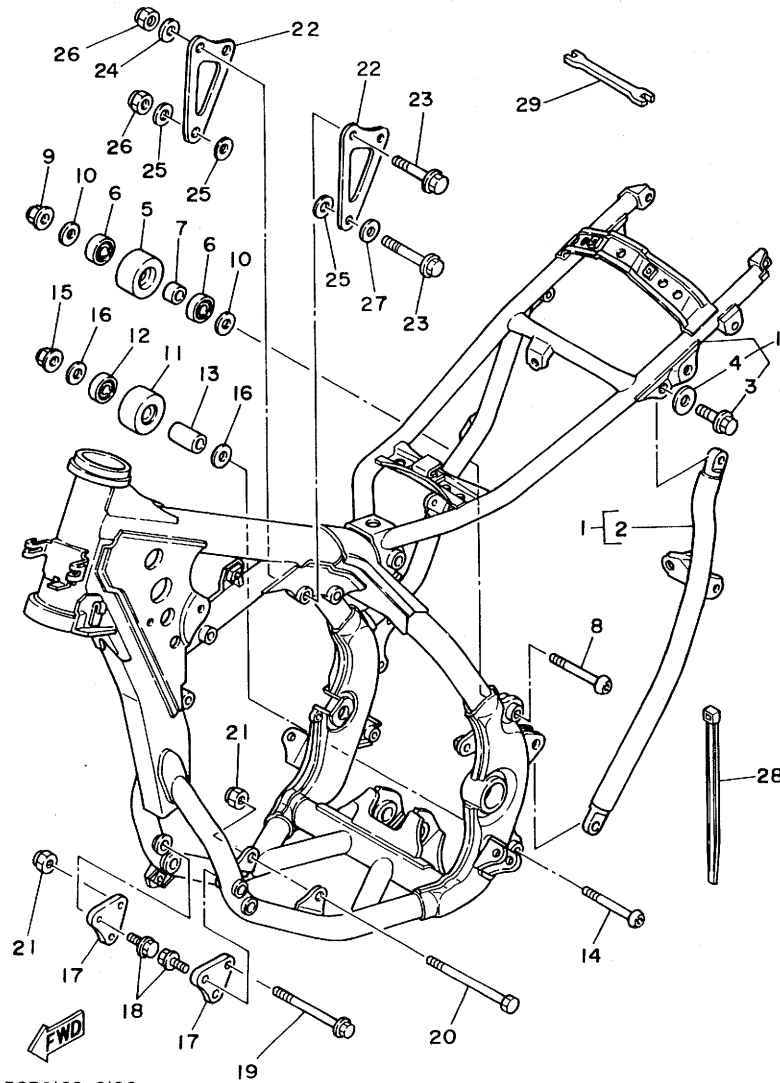

FIG. 16 FRAME

REF. NO.	PART NO.	DESCRIPTION	Q'TY	REMARKS
1	3SR-21110-00-UJ	FRAME COMP.	1	RADICAL WHITE
2	3JD-21123-01-UJ	.BACK, stay (L.H)	1	RADICAL WHITE
3	90101-08461	.BOLT	2	
4	90201-080E2	.WASHER, plate	2	
5	3JD-22178-00	TENSIONER	1	
6	93300-60816	BEARING	2	
7	90387-087K5	COLLAR	1	
8	92011-08070	SCREW	1	
9	95601-08200	NUT, self-locking	1	
10	90201-081A6	WASHER, plate	2	
11	3JD-22178-10	TENSIONER	1	
12	93300-60816	BEARING	1	
13	90387-086N4	COLLAR	1	
14	92011-08070	SCREW	1	
15	95601-08200	NUT, self-locking	1	
16	90201-081A6	WASHER, plate	2	
17	11X-21419-00	BRACKET, engine 2	2	
18	91011-08040	BOLT, flange	4	
19	91011-08095	BOLT, flange	1	
20	90109-08386	BOLT	1	
21	95601-08200	NUT, self-locking	2	
22	11X-21425-00	BRACKET, rear upper 1	2	
23	91011-08055	BOLT, flange	3	
24	90202-08022	WASHER, plate	2	
25	90201-085E6	WASHER, plate	3	
26	95601-08200	NUT, self-locking	3	
27	90201-084K3	WASHER, plate	1	
28	12R-82591-00	BAND	1	

FIG. 16 FRAME



3SR2100-0160

REF. NO.	PART NO.	DESCRIPTION	Q'TY	REMARKS
29	56A-28166-00	WRENCH, hexagon	1	

FIG. 17 FENDER

REF. NO.	PART NO.	DESCRIPTION	Q'TY	REMARKS
1	5X6-21511-11	FENDER, front	1	WHITE
2	90387-06681	COLLAR	4	
3	90119-06063	BOLT, with washer	4	
4	11X-21611-00	FENDER, rear	1	WHITE
5	90201-06571	WASHER, plate	4	
6	90105-06553	BOLT, washer based	4	
7	39X-21642-00	GUARD, flap	1	
8	95023-06010	BOLT	2	
9	90201-06571	WASHER, plate	2	

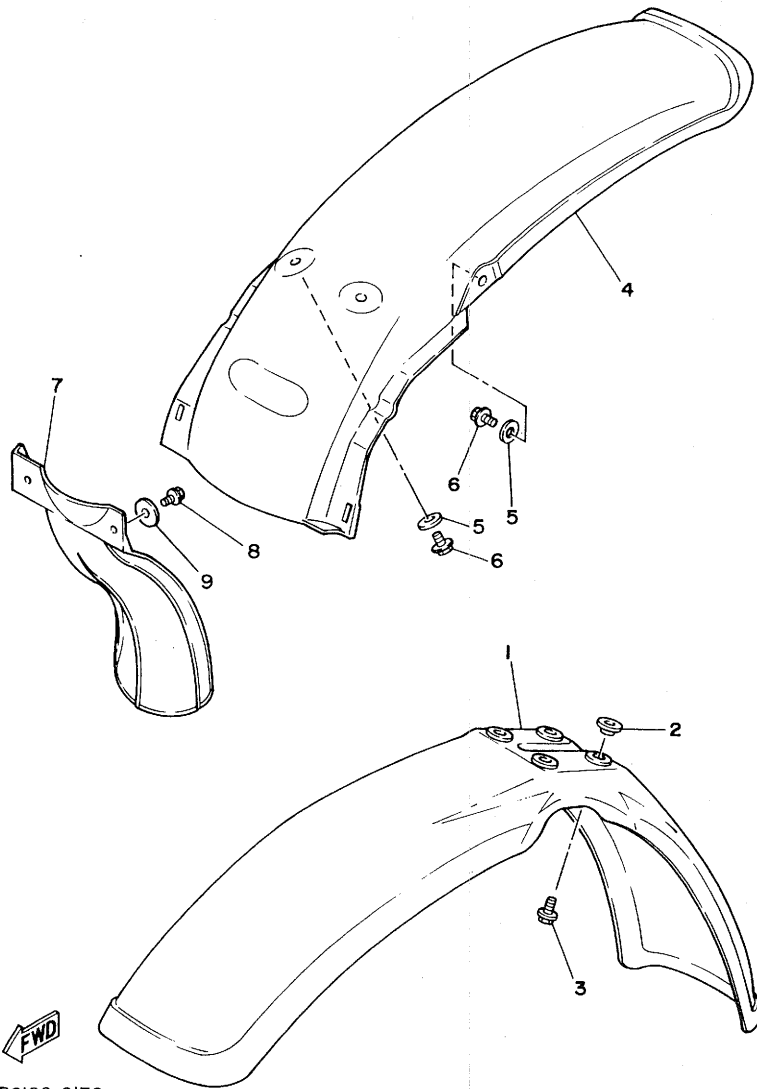

3SR2100-0170

C11

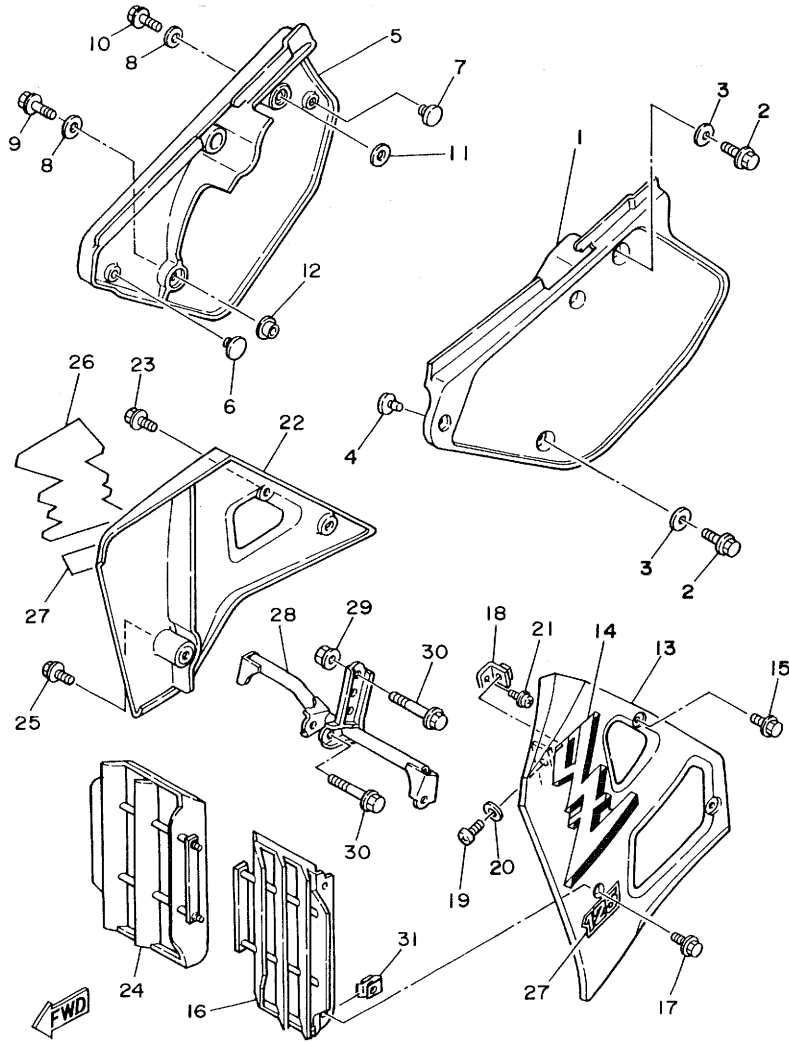

3SR2100-0180

FIG. 18 SIDE COVER

REF. NO.	PART NO.	DESCRIPTION	Q'TY	REMARKS
1	3JD-21711-00	COVER, side 1	1	
2	95023-06012	BOLT	2	
3	90201-06571	WASHER, plate	2	
4	22W-24181-00	DAMPER, locating 1	1	
5	2VM-21721-00	COVER, side 2	1	
6	22W-24181-00	DAMPER, locating 1	1	
7	3SR-24181-00	DAMPER, locating 1	1	
8	90201-06571	WASHER, plate	2	
9	95023-06020	BOLT	1	
10	95023-06012	BOLT	1	
11	92901-08200	WASHER, plain	1	
12	90387-061F9	COLLAR	1	
13	3SR-21731-00	COVER, side 3	1	
14	3JD-24244-01	GRAPHIC, fuel tank 1	1	
15	90119-06192	BOLT, with washer	2	
16	3SP-2172A-00	PANEL 1	1	
17	90119-05193	BOLT, with washer	1	
18	2VM-2172K-00	BRACKET 1	1	
19	98501-05016	SCREW, pan head	1	
20	92990-05200	WASHER, plain	1	
21	90159-05172	SCREW, with washer	1	
22	2VM-21741-00	COVER, side 4	1	
23	90119-06192	BOLT, with washer	2	
24	3SR-2172F-00	PANEL 2	1	
25	90119-05193	BOLT, with washer	2	
26	3JD-24245-01	GRAPHIC, fuel tank 2	1	
27	3JD-24254-01	GRAPHIC, fuel tank 7	2	
28	3JD-2174F-00	GUARD, radiator	1	

FIG. 18 SIDE COVER

REF. NO.	PART NO.	DESCRIPTION	Q'TY	REMARKS
29	95701-08500	NUT, flange	1	
30	95023-08050	BOLT	2	
31	22W-21791-00	NUT	4	

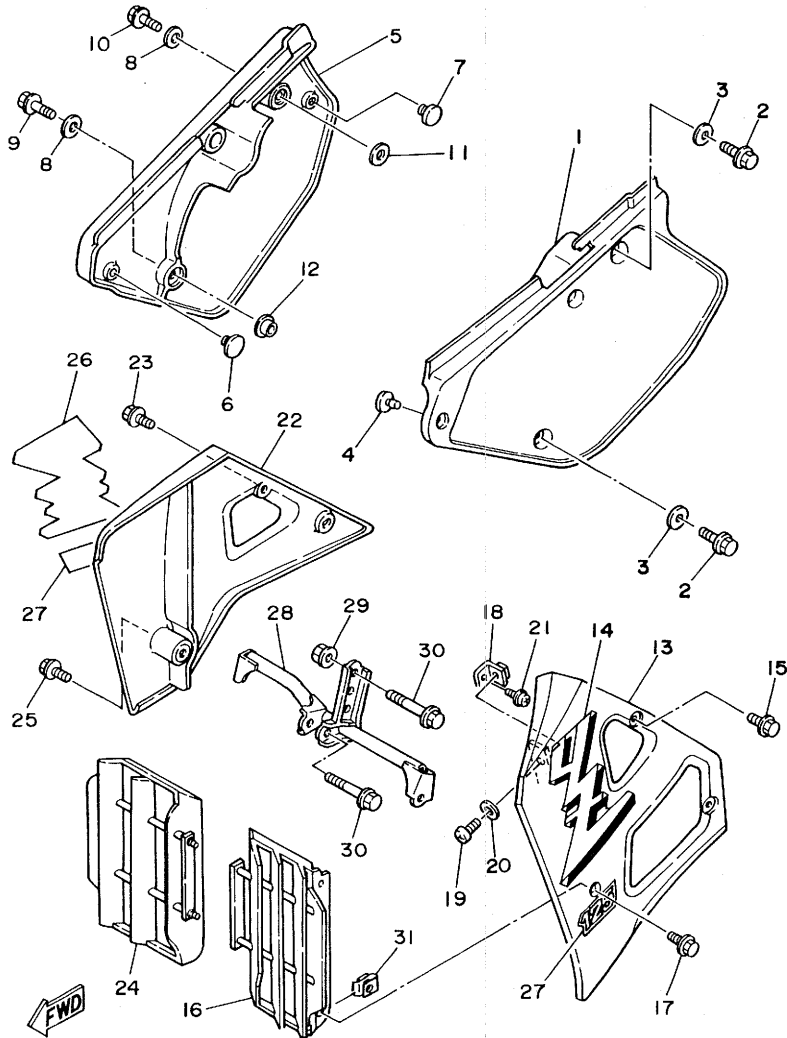

3SR2100-0180

C13

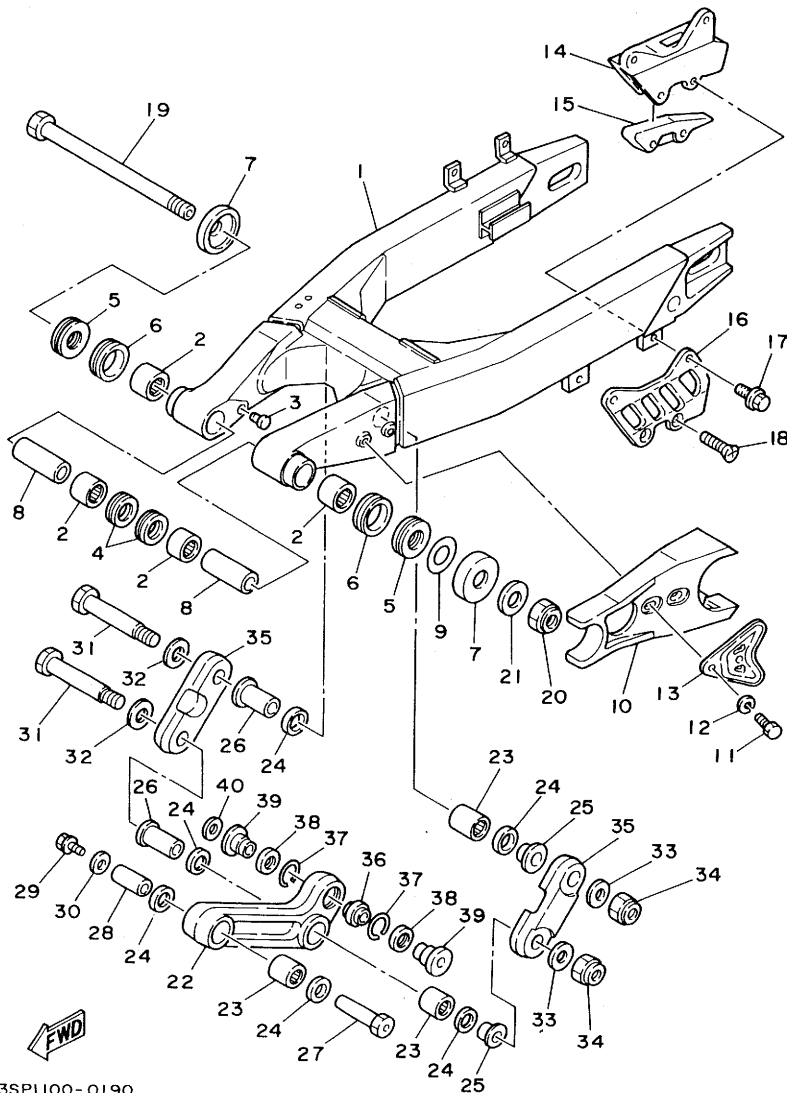

3SP1100-0190

FIG. 19 REAR ARM

REF. NO.	PART NO.	DESCRIPTION	Q'TY	REMARKS
1	3SP-22110-00	REAR ARM COMP.	1	
2	93317-22262	BEARING, cylindrical	4	UR
	93317-22263	BEARING, cylindrical	4	UR
3	90338-10150	PLUG	2	
4	93106-22019	OIL SEAL (DC 22-28-8)	2	
5	93342-22208	BEARING	2	
6	93108-35004	OIL SEAL (35-41-8)	2	
7	3R4-22129-00	COVER, thrust 2	2	
8	90380-16056	BUSH, solid	2	
9	156-22127-00	SHIM (0.3T)	1	
10	3JD-22151-00	SEAL, guard	1	
11	95023-06020	BOLT	2	
12	92990-06100	WASHER, spring	2	
13	3JD-22156-00	WASHER, plate	1	
14	3JD-22199-00	SUPPORT, chain	1	
15	3JD-22147-00	PROTECTOR, chain	1	
16	3JD-22128-00	COVER, thrust 1	1	
17	91001-06020	BOLT, flange	2	
18	92701-06035	SCREW, flat head	2	
19	1LX-22141-00	SHAFT, pivot	1	
20	90185-16127	NUT, self-locking	1	
21	90201-164H4	WASHER, plate	1	
22	3JD-2217A-00	ARM, relay	1	
23	93315-22046	BEARING, cylindrical	3	
24	93109-20029	OIL SEAL	6	
25	90387-164N2	COLLAR	2	
26	90387-164N3	COLLAR	2	
27	90179-10544	NUT	1	

C14

FIG. 19 REAR ARM

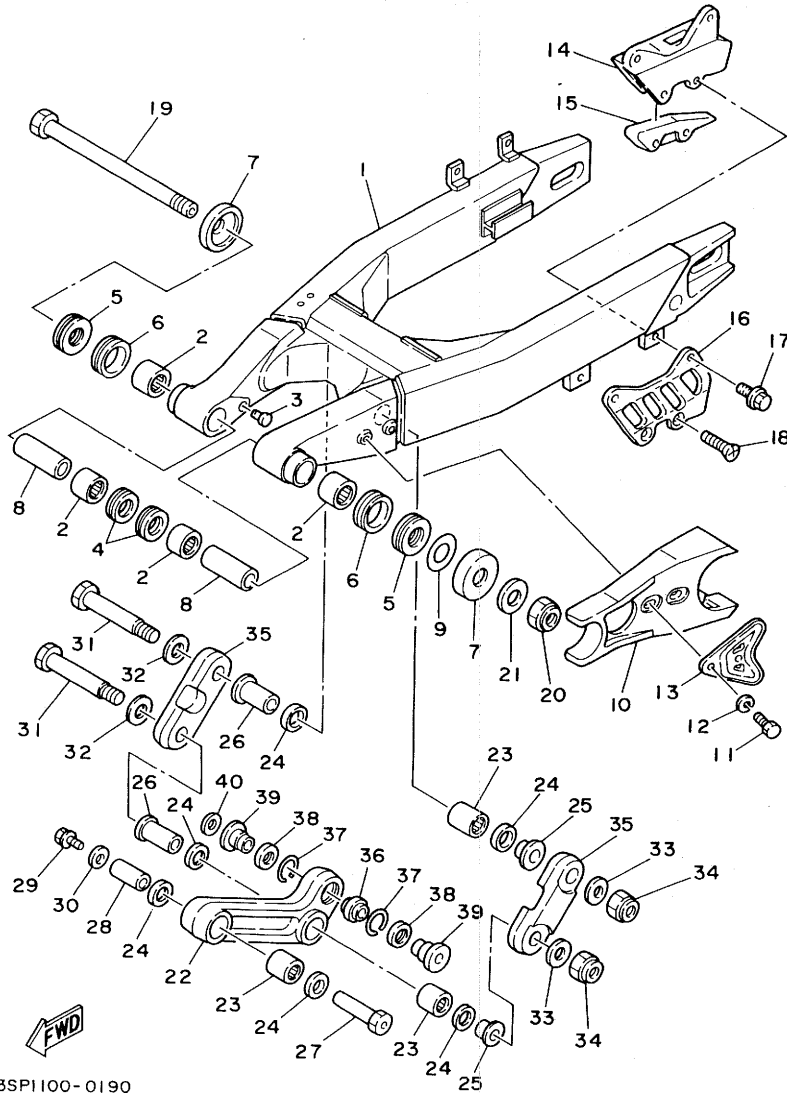

REF. NO.	PART NO.	DESCRIPTION	Q'TY	REMARKS
28	90387-167R5	COLLAR	1	
29	91011-10016	BOLT, flange	1	
30	90201-106F2	WASHER, plate	1	
31	90109-142F4	BOLT	2	
32	90201-164H4	WASHER, plate	2	
33	90201-14740	WASHER, plate	2	
34	90185-14070	NUT, self-locking	2	
35	3JD-2217F-00	ROD, connecting 1	2	
36	93399-99921	BEARING	1	
37	93440-30113	CIRCLIP	2	
38	93104-18077	OIL SEAL	2	
39	90387-102V0	COLLAR	2	
40	90201-08759	WASHER, plate	1	

3SP1100-0190

FIG. 21 STEERING

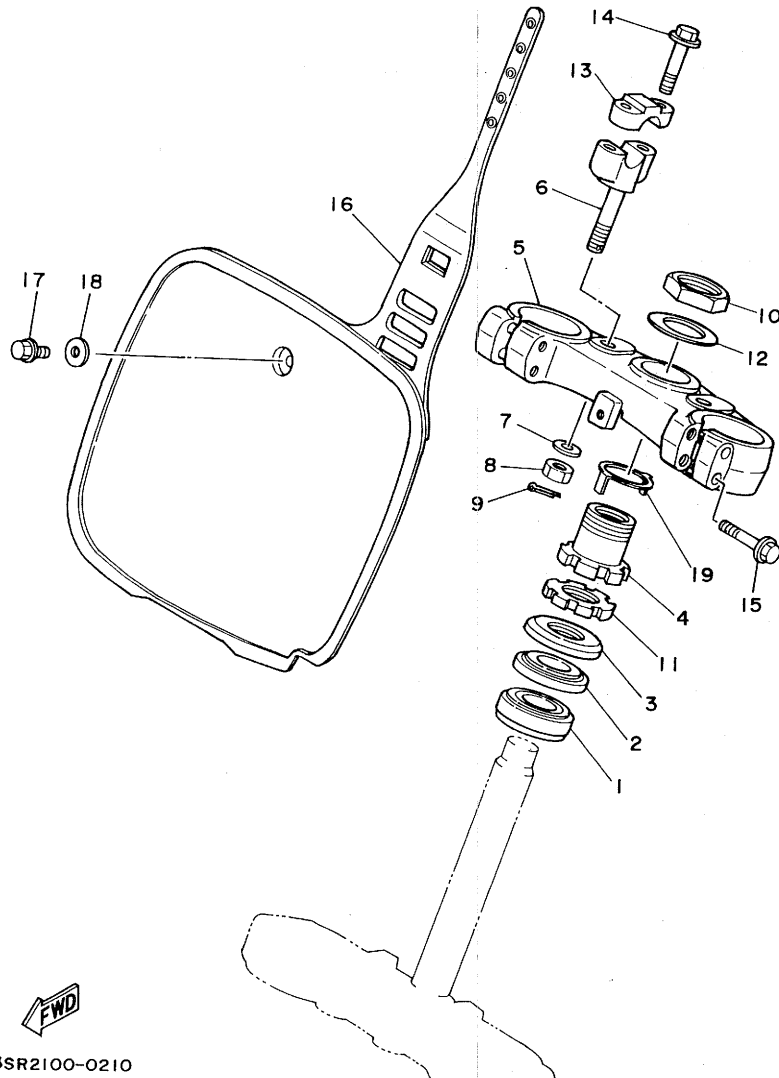

REF. NO.	PART NO.	DESCRIPTION	Q'TY	REMARKS
1	93332-00067	BEARING	1	
2	93332-00068	BEARING	1	
3	2HG-23416-00	COVER, ball race 2	1	
4	90179-28603	NUT	1	
5	3SR-23435-01	CROWN, handle	1	
6	3SR-23442-00	HOLDER, handle lower	2	
7	92990-12200	WASHER, plain	2	
8	95611-12100	NUT, u	2	
9	91401-25020	PIN, cotter	2	
10	90170-36394	NUT	1	
11	90179-28602	NUT	1	
12	90201-365M5	WASHER, plate	1	
13	3SP-23441-00	HOLDER, handle upper	2	
14	95023-08035	BOLT	4	
15	95023-08050	BOLT	4	
16	5X6-23485-11	PLATE, number	1	CLEAN WHITE
17	95023-06012	BOLT	1	
18	90201-06571	WASHER, plate	1	
19	3SP-23418-00	WASHER, special	1	



3SR2100-0210

D3

FIG. 22 FRONT FORK

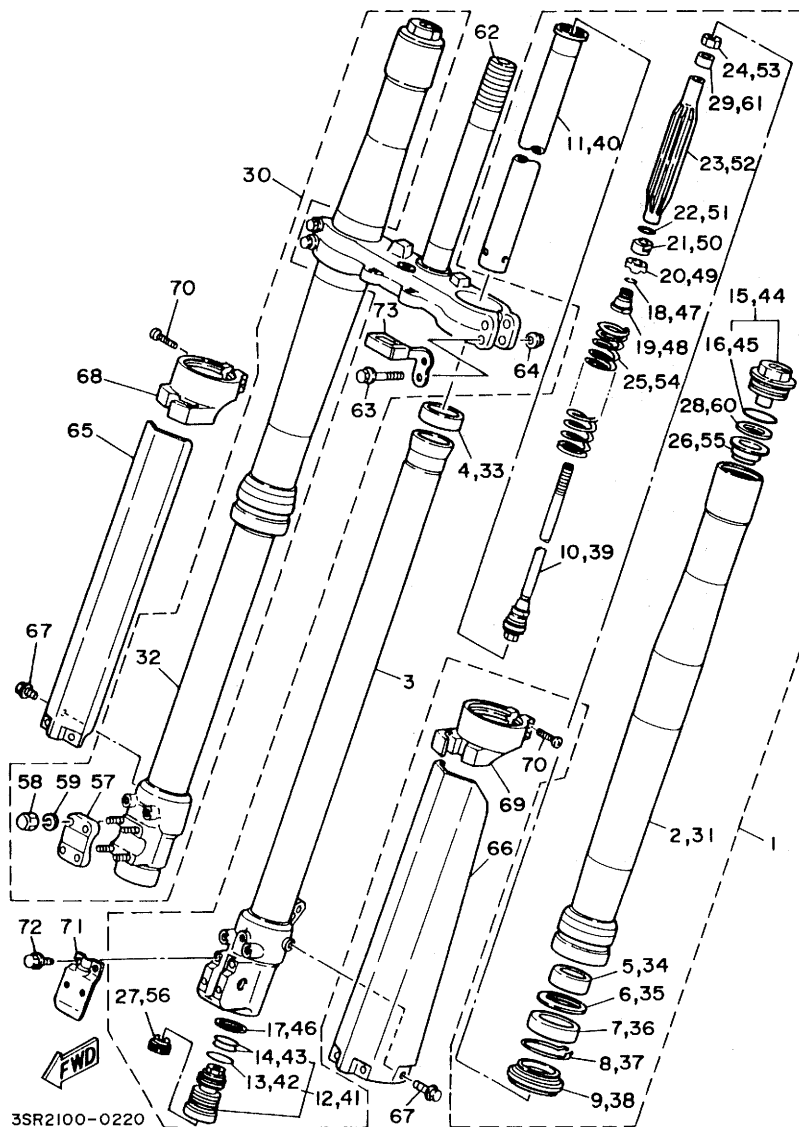

REF. NO.	PART NO.	DESCRIPTION	Q'TY	REMARKS
1	3SR-23102-L0	FRONT FORK ASSY (L.H)	1	UR
	3SR-23102-M0	FRONT FORK ASSY (L.H)	1	UR EUROPE
2	3SP-23136-L0	.TUBE, outer 2	1	
3	3SP-23120-L0	.INNER TUBE COMP. 2	1	
4	3JD-23171-L0	.PISTON, front fork	1	
5	3JD-23125-L0	.METAL, slide 1	1	
6	36Y-23146-10	.WASHER, oil seal	1	
7	3SP-23145-L0	.OIL SEAL	1	
8	26H-23156-00	.CLIP, oil seal	1	
9	3SP-23144-L0	.SEAL, dust	1	
10	3SP-2314A-L0	.PISTON ROD ASSY	1	
11	3SP-23170-L0	.CYLINDER COMP., front fork	1	
12	3SR-2316A-L0	.VALVE COMP.	1	UR
	3SR-2316A-M0	.VALVE COMP.	1	UR FOR EUROPE
13	3SP-23147-L0	..O-RING	1	
14	3JD-23147-M0	..O-RING	2	
15	3SP-23111-L0	.BOLT, cap	1	
16	3SP-23147-M0	..O-RING	1	
17	3JD-23158-L0	.GASKET	1	
18	3SP-23153-L0	.RING, snap	2	
19	3SP-23113-L0	.COLLAR	1	
20	3SP-23166-L0	.SPACER, oil lock	1	
21	3SP-23393-L0	.NUT, special	1	
22	3JD-23147-L0	.O-RING	1	
23	3SP-23142-L0	.SEAT, spring upper	1	
24	3SP-23357-L0	.NUT	1	
25	3JD-23141-M0	.SPRING, front fork (K=0.365)	1	
26	3SR-23143-L0	.SEAT, spring lower	1	

D4

FIG. 22 FRONT FORK

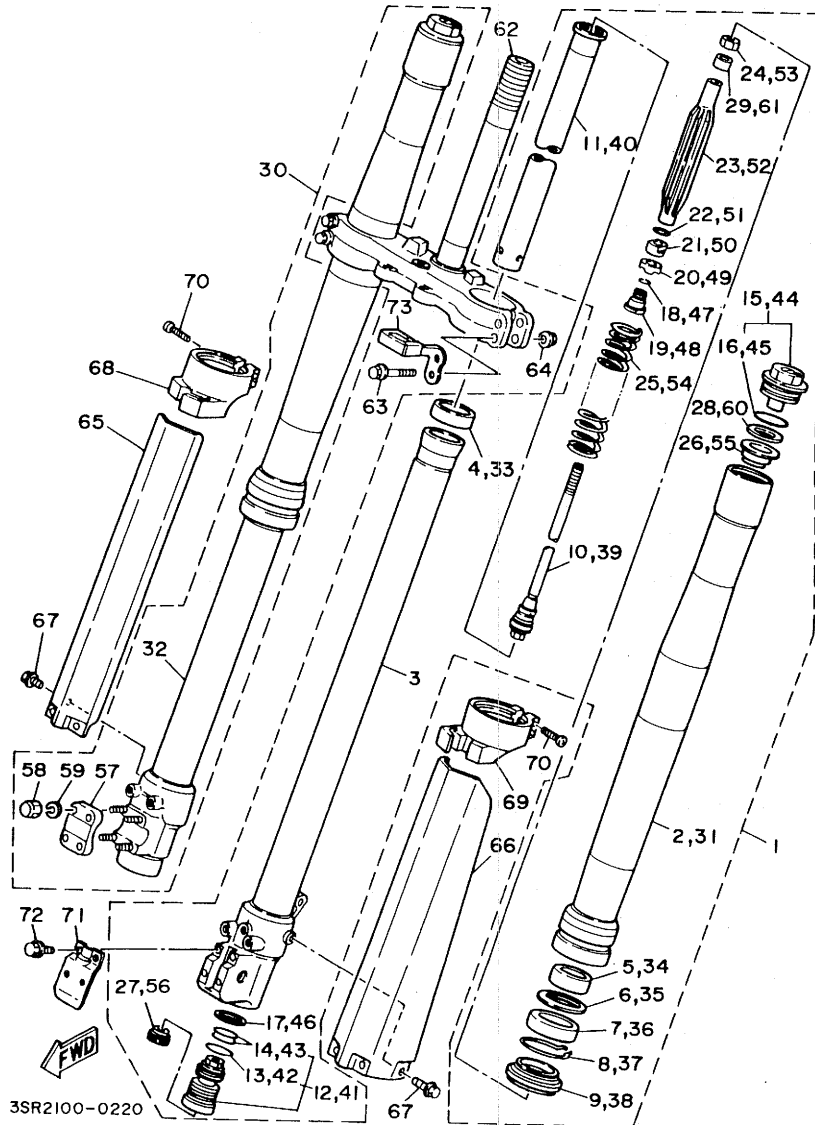

3SR2100-0220

REF. NO.	PART NO.	DESCRIPTION	Q'TY	REMARKS
27	3JD-2312G-L0	.PLUG	1	
28	3SR-23146-M0	.WASHER	1	
29	3SP-23364-L0	.COLLAR 2	2	FOR EUROPE
30	3SR-23103-L0	FRONT FORK ASSY (R.H)	1	UR
	3SP-23103-M0	FRONT FORK ASSY (R.H)	1	UR FOR EUROPE
31	3SP-23136-L0	.TUBE, outer 2	1	
32	3SP-23110-L0	.INNER TUBE COMP. 1	1	
33	3JD-23171-L0	.PISTON, front fork	1	
34	3JD-23125-L0	.METAL, slide 1	1	
35	36Y-23146-10	.WASHER, oil seal	1	
36	3SP-23145-L0	.OIL SEAL	1	
37	26H-23156-00	.CLIP, oil seal	1	
38	3SP-23144-L0	.SEAL, dust	1	
39	3SP-2314A-L0	.PISTON ROD ASSY	1	
40	3SP-23170-L0	.CYLINDER COMP., front fork	1	
41	3SR-2316A-L0	.VALVE COMP.	1	UR
	3SR-2316A-M0	.VALVE COMP.	1	UR FOR EUROPE
42	3SP-23147-L0	..O-RING	1	
43	3JD-23147-M0	..O-RING	2	
44	3SP-23111-L0	.BOLT, cap	1	
45	3SP-23147-M0	..O-RING	1	
46	3JD-23158-L0	.GASKET	1	
47	3SP-23153-L0	.RING, snap	2	
48	3SP-23113-L0	.COLLAR	1	
49	3SP-23166-L0	.SPACER, oil lock	1	
50	3SP-23393-L0	.NUT, special	1	
51	3JD-23147-L0	.O-RING	1	
52	3SP-23142-L0	.SEAT, spring upper	1	

D5

FIG. 22 FRONT FORK

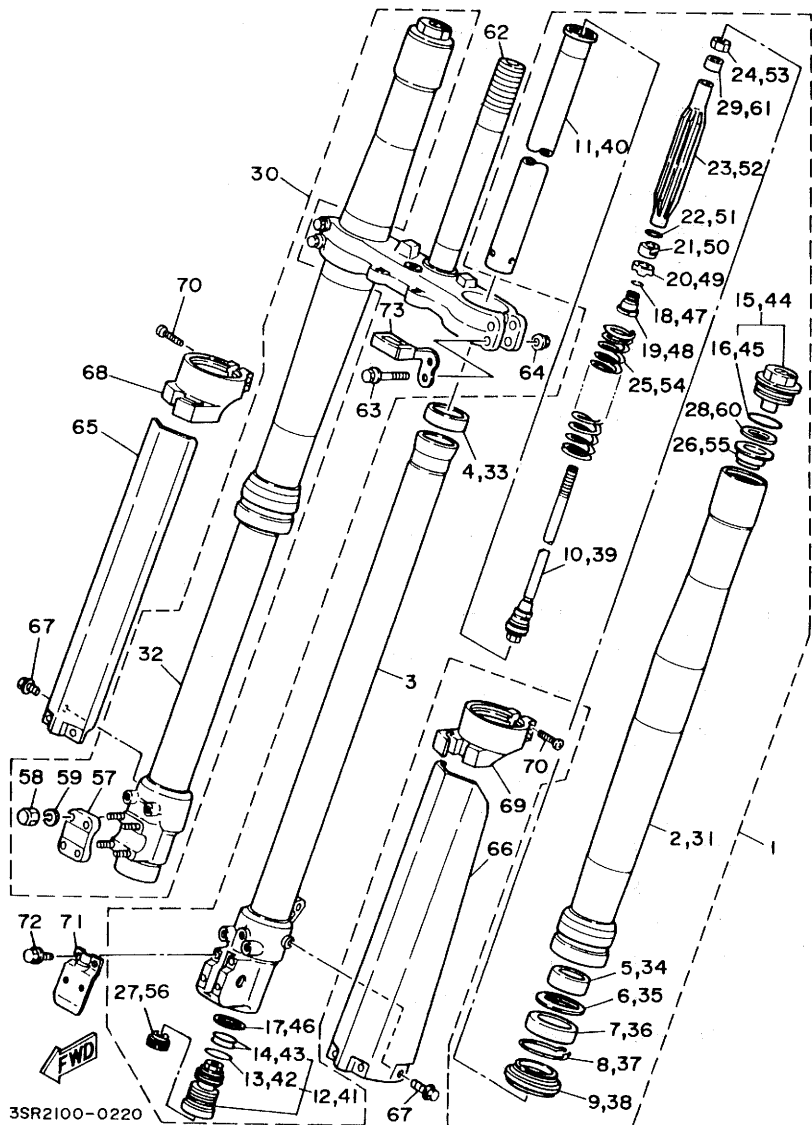

REF. NO.	PART NO.	DESCRIPTION	Q'TY	REMARKS
53	3SP-23357-LO	.NUT	1	
54	3JD-23141-MO	.SPRING, front fork (K=0.365)	1	
55	3SR-23143-LO	.SEAT, spring lower	1	
56	3JD-23126-LO	.PLUG	1	
57	4V2-23167-LO	.HOLDER, axle	1	
58	5Y3-23393-00	.NUT, special	4	
59	92990-06100	.WASHER, spring	4	
60	3SR-23146-MO	.WASHER	1	
61	3SP-23364-LO	.COLLAR 2	2	FOR EUROPE
62	3JD-23340-LO	UNDER BRACKET COMP.	1	
63	95021-08060	BOLT, flange	4	
64	95701-08500	NUT, flange	4	
65	3SP-2314J-LO	PROTECTOR COMP., 2	1	
66	3SP-2314H-LO	PROTECTOR COMP., 1	1	
67	3SP-23356-LO	BOLT 2	6	
68	3SP-2314G-LO	PROTECTOR GUIDE COMP., 2	1	
69	3SP-2314F-LO	PROTECTOR GUIDE COMP., 1	1	
70	4V4-23194-LO	SCREW, boot band	4	
71	3SP-2314E-LO	COVER, hose	1	
72	3SP-23346-LO	BOLT 1	4	
73	3JD-23389-01	GUIDE, cable	1	

FIG. 23 FUEL TANK

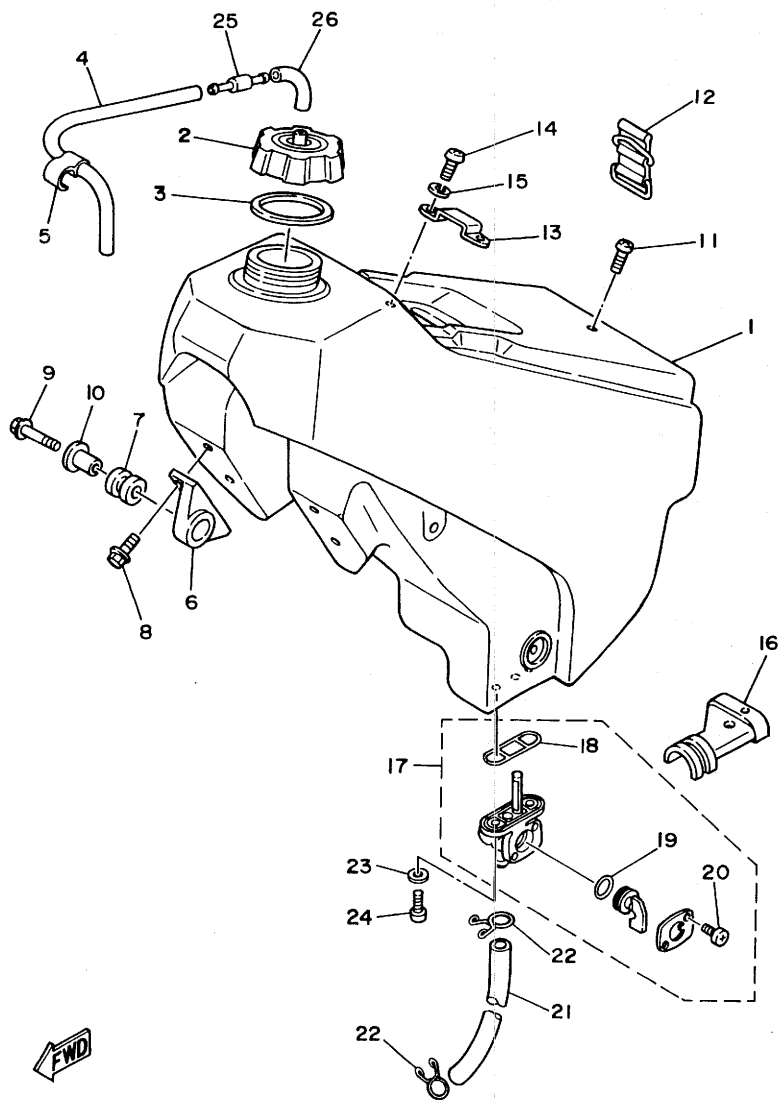

REF. NO.	PART NO.	DESCRIPTION	Q'TY	REMARKS
1	3JD-24110-00	FUEL TANK COMP.	1	
2	5X7-24611-01	BODY, cap	1	
3	5X7-24612-00	GASKET, cap	1	
4	90445-09100	HOSE	1	
5	90468-15064	CLIP	1	
6	24X-24144-00	HOLDER, damper	2	
7	90480-18354	GROMMET	2	
8	95023-06016	BOLT	4	
9	95023-06035	BOLT	2	
10	3JD-24186-00	WASHER, special	2	
11	98980-06020	SCREW, bind	1	
12	3SP-24173-00	BAND, tank fitting 1	1	
13	5X6-2412F-00	BRACKET, seat	1	
14	92501-06012	SCREW, pan head	2	
15	92990-06100	WASHER, spring	2	
16	1LX-24181-00	DAMPER, locating 1	1	
17	3JD-24500-00	FUEL COCK ASSY 1	1	
18	4X8-24512-00	.O-RING	1	
19	4X8-24534-00	.SEAL, cock	1	
20	98503-03008	.SCREW, pan head	2	
21	90445-11452	HOSE	1	
22	90467-10008	CLIP	2	
23	90202-06010	WASHER, plate	2	
24	90149-06011	SCREW	2	
25	4A0-24380-00	PIPE JOINT ASSY	1	
26	90445-09058	HOSE	1	

3SR2100-0230

D7

FIG. 24 SEAT

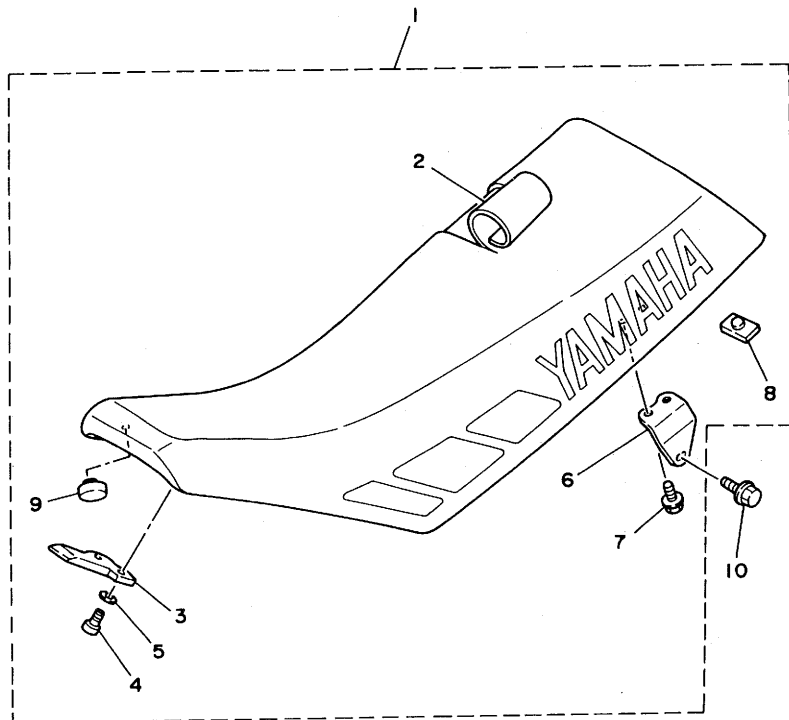

REF. NO.	PART NO.	DESCRIPTION	Q'TY	REMARKS
1	3JD-24770-10	SEMI-DOUBLE SEAT ASSY	1	UR
	3SP-24770-00	SEMI-DOUBLE SEAT ASSY	1	UR FOR JAPAN
2	3JD-24731-10	.COVER, seat	1	UR
	3SP-24771-00	.COVER, seat	1	UR FOR JAPAN
3	5X6-24748-10	.BRACKET, seat	1	
4	92501-06012	.SCREW, pan head	2	
5	92901-06200	.WASHER, plain	2	
6	1LX-24738-01	.BRACKET, seat	2	
7	95023-06012	.BOLT	4	
8	509-24724-00	.DAMPER, seat	1	
9	107-24741-00	.PAD, seat	2	
10	95023-08016	BOLT	2	



3SP1100-0240

D8

FIG. 25 FRONT WHEEL

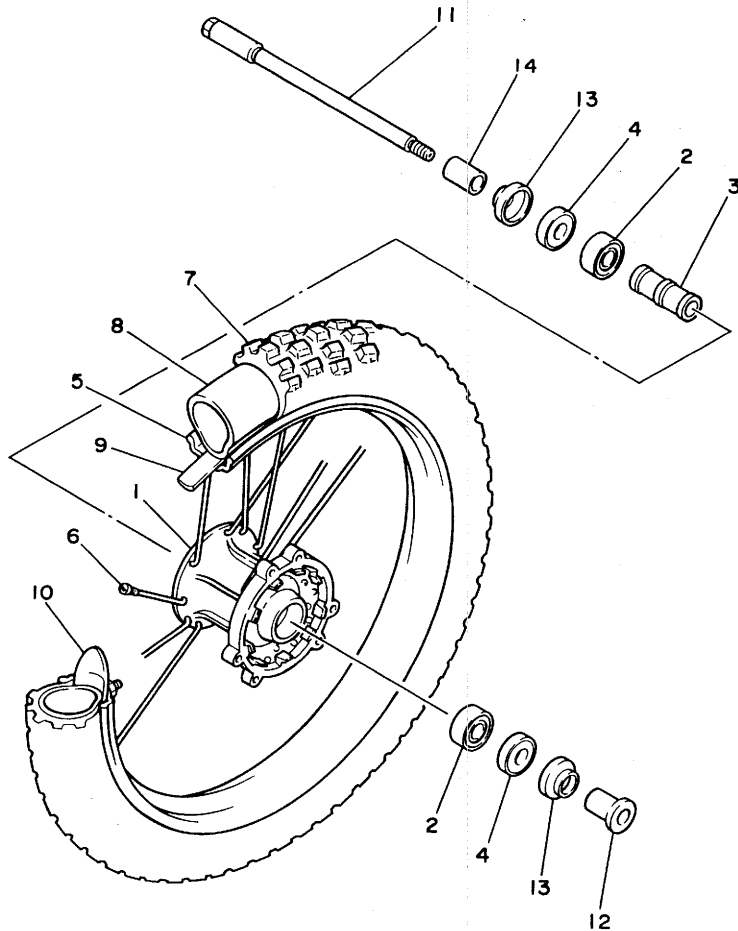

REF. NO.	PART NO.	DESCRIPTION	Q'TY	REMARKS
1	3SP-25111-00	HUB, front	1	
2	93306-20209	BEARING (B6202)	2	
3	90560-15352	SPACER	1	
4	93102-20281	OIL SEAL (SD 20-35-5)	2	
5	94416-21453	RIM (1.60-21)	1	
6	1LX-25104-00	SPOKE SET, front	1	
7	94108-216U5	TIRE (80/100-21 51M D704F P) FOR EUROPE	1	UR DUNLOP
	94108-219U5	TIRE (80/100-21 K990) FOR U.S.A., CANADA, S.AFRICA, OTHERS	1	UR DUNLOP
	94108-215H9	TIRE (80/100-21 4PR) FOR OCEANIA, JAPAN	1	UR BRIDGESTONE
8	94227-21123	TUBE (2.75-21) FOR U.S.A., CANADA, EUROPE, S.AFRICA, OTHERS	1	UR BRIDGESTONE
	94209-21229	TUBE (80/100C-21 TR4) FOR OCEANIA, JAPAN	1	UR BRIDGESTONE
9	94307-21145	BAND, rim (70-80/100-21) FOR U.S.A., CANADA, EUROPE, S.AFRICA, OTHERS	1	UR DUNLOP
	94330-21084	BAND, rim (3.00-21) FOR OCEANIA, JAPAN	1	UR BRIDGESTONE
10	5X2-25394-00	SPACER, bead	1	
11	55U-25181-01	AXLE, wheel	1	
12	90387-152V1	COLLAR	1	
13	322-25118-00	COVER, hub dust	2	
14	90387-151V9	COLLAR	1	



3JD1010-9250

D9

FIG. 26 FRONT BRAKE CALIPER

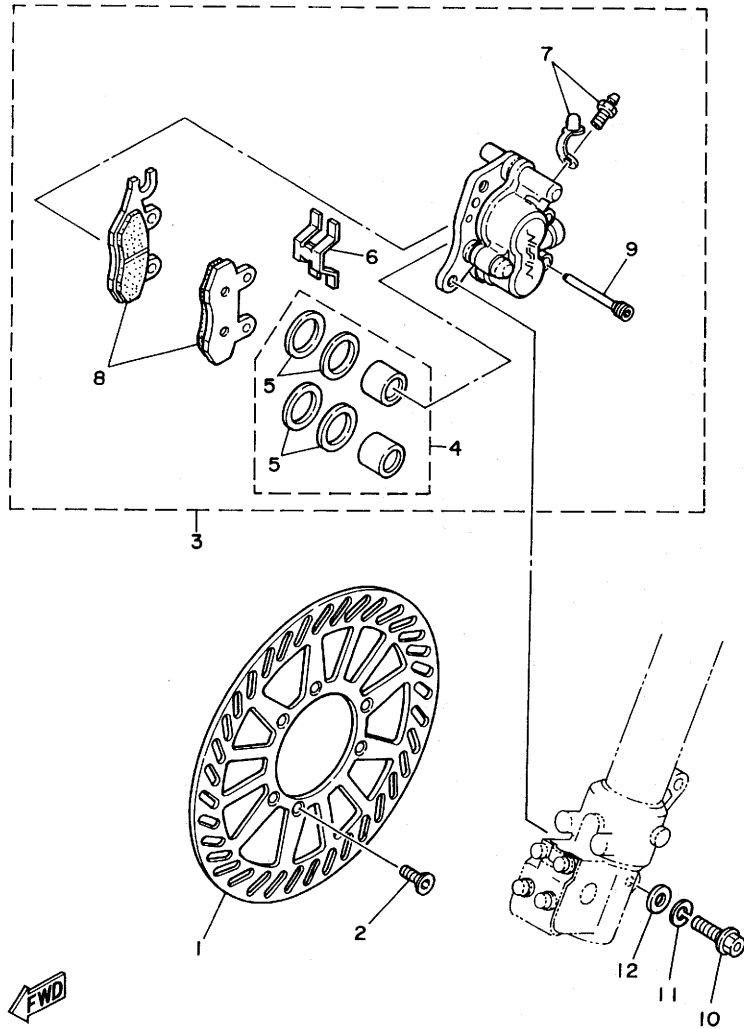

REF. NO.	PART NO.	DESCRIPTION	Q'TY	REMARKS
1	3SP-2582T-00	DISC, brake	1	
2	90149-06272	SCREW	6	
3	3SP-2580T-00	CALIPER ASSY (LEFT)	1	
4	3JD-W0057-00	.PISTON ASSY, caliper	1	
5	3JD-W0047-00	..CALIPER SEAL KIT	1	
6	3JD-25919-00	.SUPPORT, pad	1	
7	1UY-W0048-50	.BREED SCREW KIT	1	
8	3SP-W0045-00	.BRAKE PAD KIT	1	
9	3GD-25933-00	.PIN, pad	2	
10	97301-08040	BOLT	2	
11	92990-08100	WASHER, spring	2	
12	92901-08600	WASHER, plate	2	



3SP1100-0260

D10

FIG. 27 REAR WHEEL

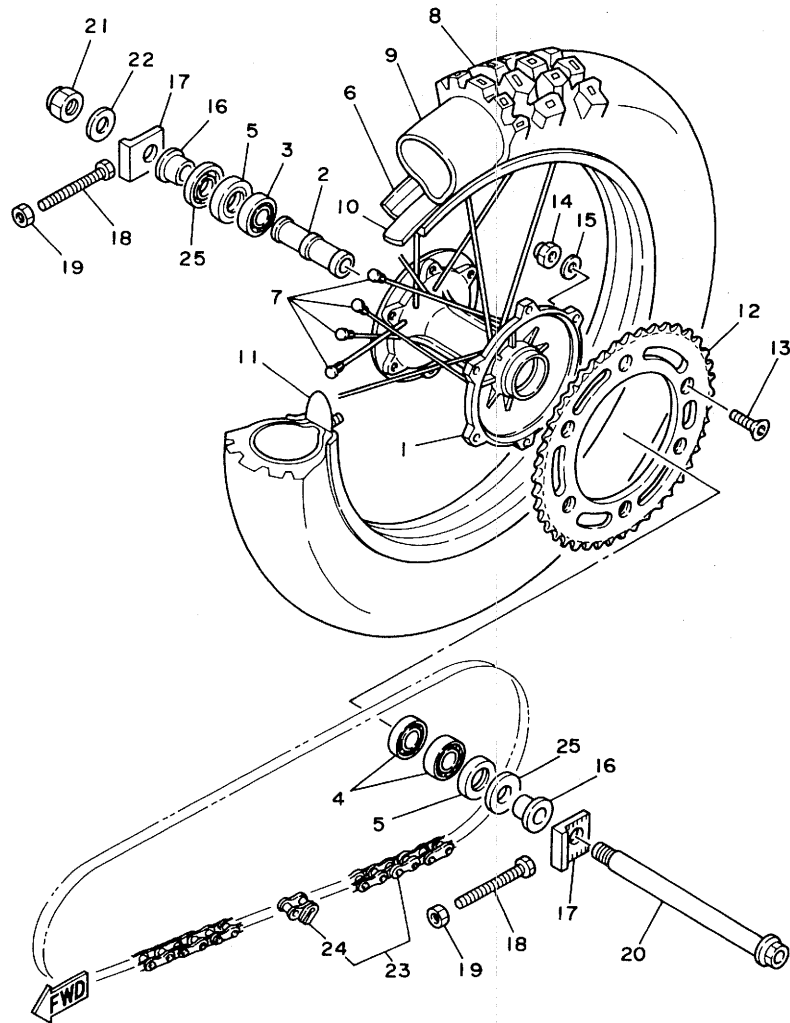

3SP1100-0270

REF. NO.	PART NO.	DESCRIPTION	Q'TY	REMARKS
1	3SP-25311-00	HUB, rear	1	
2	3JD-25317-00	SPACER, bearing	1	
3	93306-00418	BEARING	1	
4	93306-00438	BEARING	2	
5	93106-28023	OIL SEAL	2	
6	94418-19485	RIM (1.85-19)	1	
7	3JD-25304-00	SPOKE SET, rear	1	
8	94110-196W6	TIRE (100/90-19 57M K695 P) FOR EUROPE	1	UR DUNLOP
	94110-199U4	TIRE (100/90-19 K990) FOR U.S.A., CANADA, S.AFRICA, OTHERS	1	UR DUNLOP
	94110-196W3	TIRE (100/90-19 M22) FOR OCEANIA, JAPAN	1	UR BRIDGESTONE
9	94210-19224	TUBE (100/90-19 TR4 BTL) FOR U.S.A., CANADA, EUROPE, S.AFRICA, OTHERS	1	UR DUNLOP
	94210-19222	TUBE (3.25-19) FOR OCEANIA, JAPAN	1	UR BRIDGESTONE
10	94327-19111	BAND, rim (2.75-19) FOR U.S.A., CANADA, EUROPE, S.AFRICA, OTHERS	1	UR INOUE
	94316-19156	BAND, rim (1.85-19) FOR OCEANIA, JAPAN	1	UR BRIDGESTONE
11	2X3-25394-00	SPACER, bead	2	
12	39W-25450-00	SPROCKET, driven (50T)	1	UR STD FOR EUROPE
	3JD-25451-01	SPROCKET, driven (51T)	1	UR STD
	39W-25444-01	SPROCKET, driven (44T)	1	AP
	39W-25445-01	SPROCKET, driven (45T)	1	AP
	39W-25446-01	SPROCKET, driven (46T)	1	AP
	39W-25448-00	SPROCKET, driven (48T)	1	AP
	39W-25452-01	SPROCKET, driven (52T)	1	AP
	2HH-25449-00	SPROCKET, driven (49T)	1	AP
13	90109-08792	BOLT	6	
14	95611-08100	NUT, u	6	
15	90201-081A6	WASHER, plate	6	
16	90387-203V0	COLLAR	2	
17	3SP-25388-00	PULLER, chain 1	2	

D11

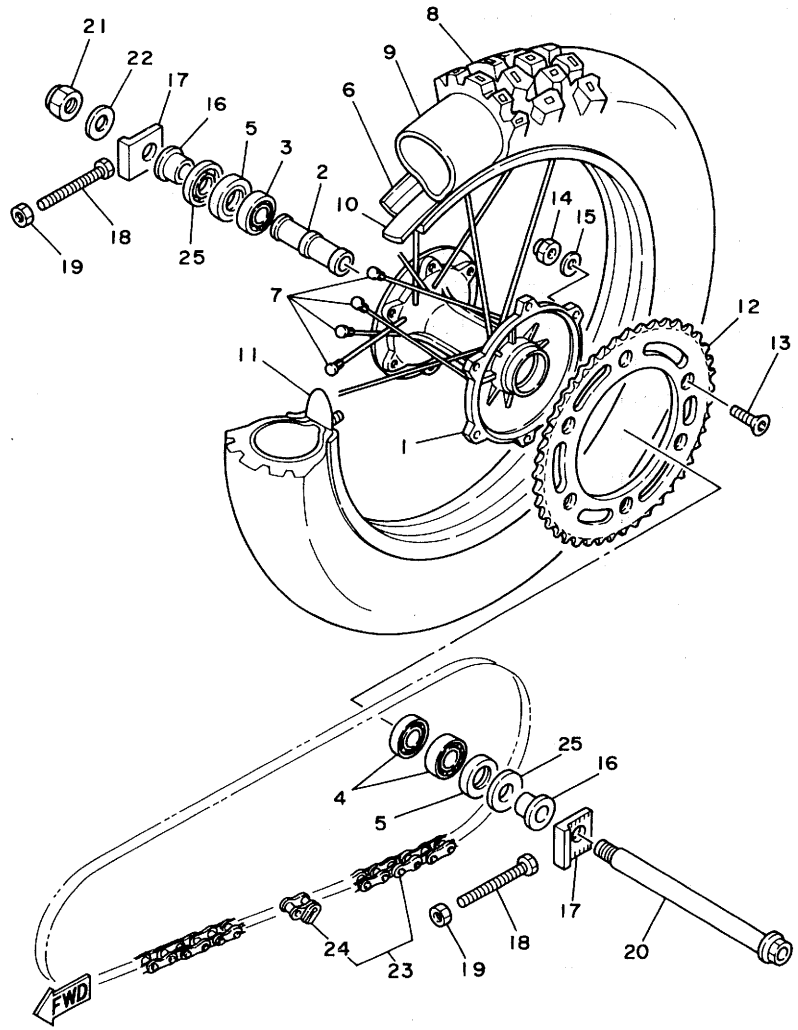

FIG. 27 REAR WHEEL

REF. NO.	PART NO.	DESCRIPTION	Q'TY	REMARKS
18	90101-08699	BOLT	2	
19	95701-08500	NUT, flange	2	
20	3JD-25381-01	AXLE, wheel	1	
21	90185-18104	NUT, self-locking	1	
22	92990-18600	WASHER	1	
23	94581-13116	CHAIN	1	
24	94681-13001	JOINT, chain	1	
25	4V4-25367-00	COVER, hub dust	2	

3SPI100-0270

D12

FIG. 28 REAR BRAKE CALIPER

REF. NO.	PART NO.	DESCRIPTION	Q'TY	REMARKS
1	3JD-2582W-00	DISC, rear brake 2	1	
2	90149-06272	SCREW	6	
3	3SP-2580W-00	CALIPER ASSY, rear 2	1	
4	3SP-W0057-50	.PISTON ASSY, caliper	1	
5	3JD-W0047-50	..CALIPER SEAL KIT	1	
6	3SP-25919-51	.SUPPORT, pad	1	
7	1UY-W0048-50	.BREED SCREW KIT	1	
8	3SP-W0046-00	.BRAKE PAD KIT, 2	1	
9	3GD-25827-00	.SHIM, caliper	1	
10	3SP-25924-51	.PIN, pad	2	
11	3SP-25920-00	SUPT. BRKT. ASSY	1	
12	91311-08025	BOLT	2	
13	3JD-27491-00	PROTECTOR	1	
14	92011-06012	SCREW	2	

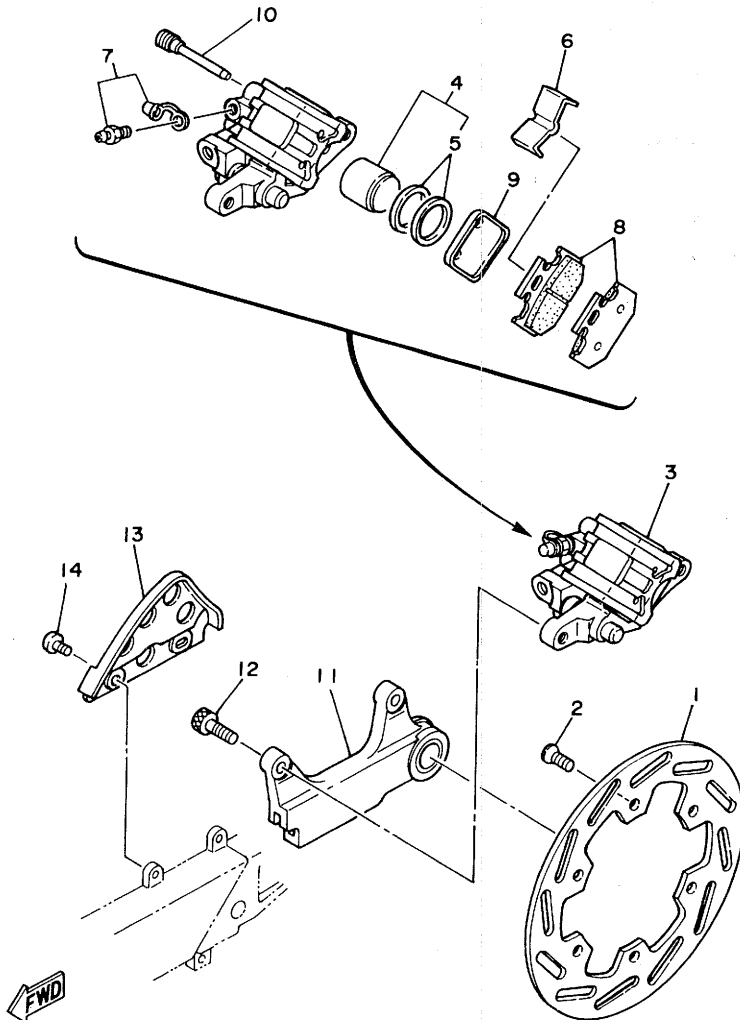

3SPI100-0280

D13

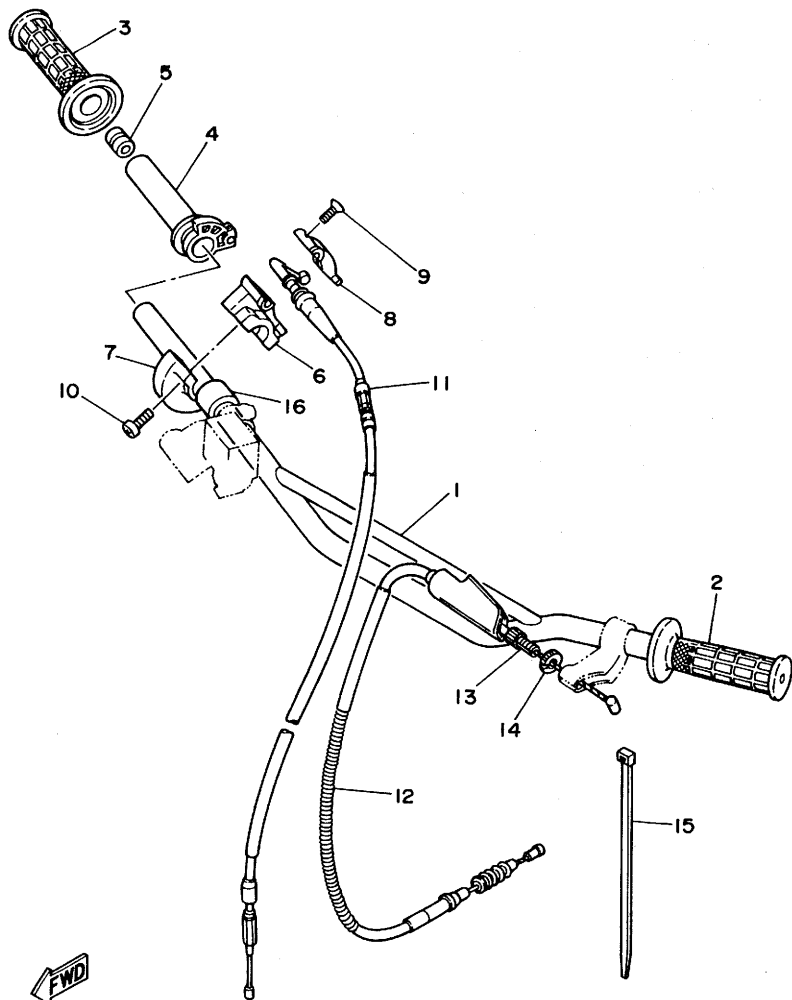

FIG. 29 STEERING HANDLE. CABLE

REF. NO.	PART NO.	DESCRIPTION	Q'TY	REMARKS
1	3SP-26111-00	HANDLEBAR	1	
2	1LX-26241-01	GRIP	1	
3	1LX-26242-01	GRIP (R.H)	1	
4	23X-26243-00	TUBE, throttle guide	1	
5	688-82535-00	GROMMET	1	
6	23X-26281-00	CAP, grip upper	1	
7	431-26282-01-98	CAP, grip lower	1	LOW GLOSS BLACK
8	5X2-2628H-01	CAP, wire	1	
9	98706-04012	SCREW, flat head	2	
10	98506-05016	SCREW, pan head	2	
11	3JD-26311-00	CABLE, throttle 1	1	
12	3JD-26335-00	CABLE, clutch	1	
13	90123-08090	BOLT	1	
14	90179-08401	NUT	1	
15	90465-13154	CLAMP	1	
16	90560-22281	SPACER	1	

3JD1010-9290

D14

FIG. 30 FRONT MASTER CYLINDER

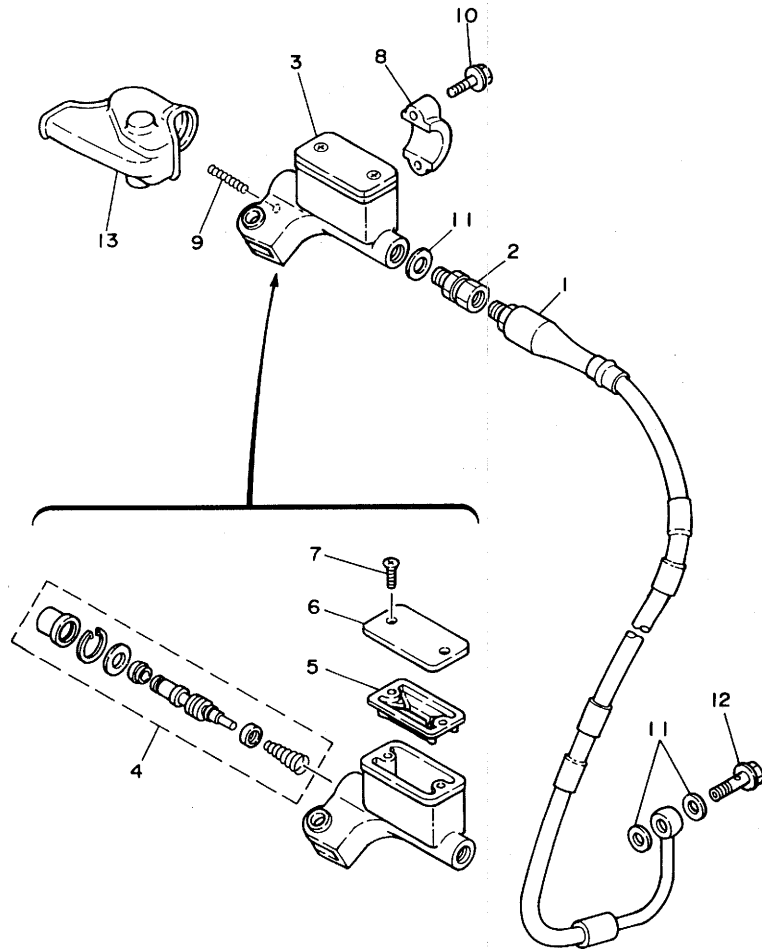

REF. NO.	PART NO.	DESCRIPTION	Q'TY	REMARKS
1	3SP-25872-00	HOSE, brake 1	1	
2	3LC-25885-00	JOINT	1	
3	3SP-25870-00	MASTER CYLINDER SUB ASSY	1	
4	3SP-W0041-00	.CYLINDER KIT, master	1	
5	56A-25854-00	.DIAPHRAGM, reservoir	1	
6	2VN-25852-00	.CAP, reservoir	1	
7	98706-04012	.SCREW, flat head	2	
8	56A-25867-00	BRACKET, master cylinder	1	
9	90501-06162	SPRING, compression	1	
10	95026-06025	BOLT, flange	2	
11	90201-10118	WASHER, plate	3	
12	90401-10034	BOLT, union	1	
13	56A-26372-00	COVER, handle lever 1	1	



3SP1100-0300

D15

FIG. 31 STAND, FOOTREST

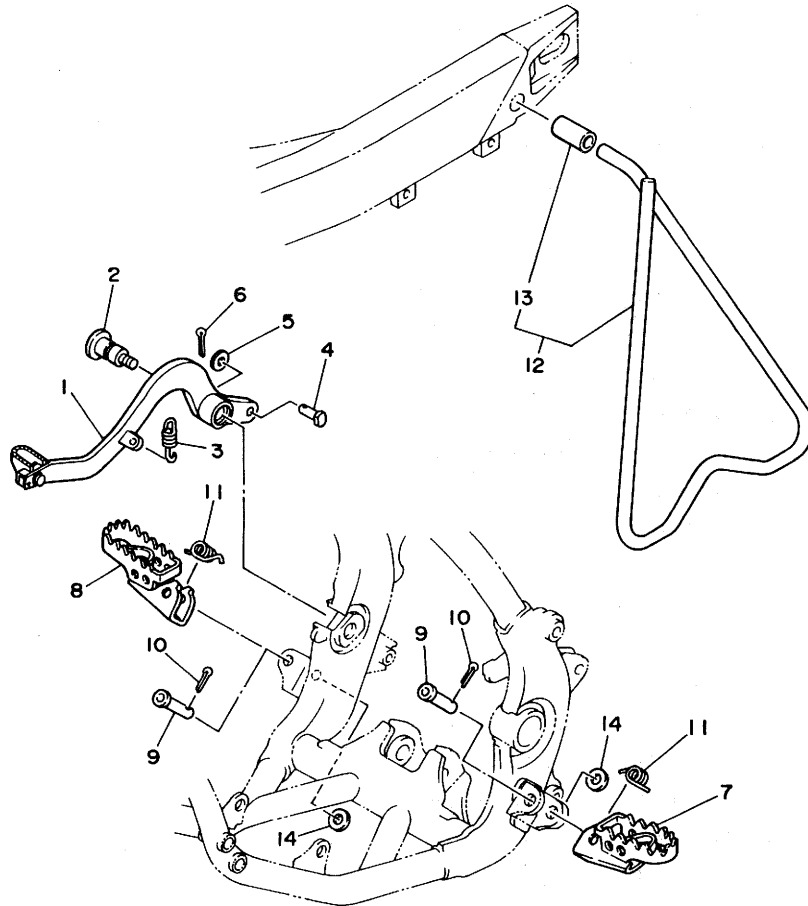

REF. NO.	PART NO.	DESCRIPTION	Q'TY	REMARKS
1	3JD-27200-01	PEDAL, brake	1	
2	3JD-27217-00	BOLT	1	
3	90506-14453	SPRING, tension	1	
4	90240-08120	PIN, clevis	1	
5	92901-08600	WASHER, plate	1	
6	91401-25015	PIN, cotter	1	
7	3SP-27411-00	FOOTREST 1	1	
8	3SP-27421-00	FOOTREST 2	1	
9	90240-10117	PIN, clevis	2	
10	91401-25015	PIN, cotter	2	
11	90508-28777	SPRING, torsion	2	
12	3SP-27300-00	SIDE STAND ASSY	1	
13	90445-162A0	.HOSE	1	
14	90201-10119	WASHER, plate	2	



3SR2100-0310

FIG. 32 REAR MASTER CYLINDER

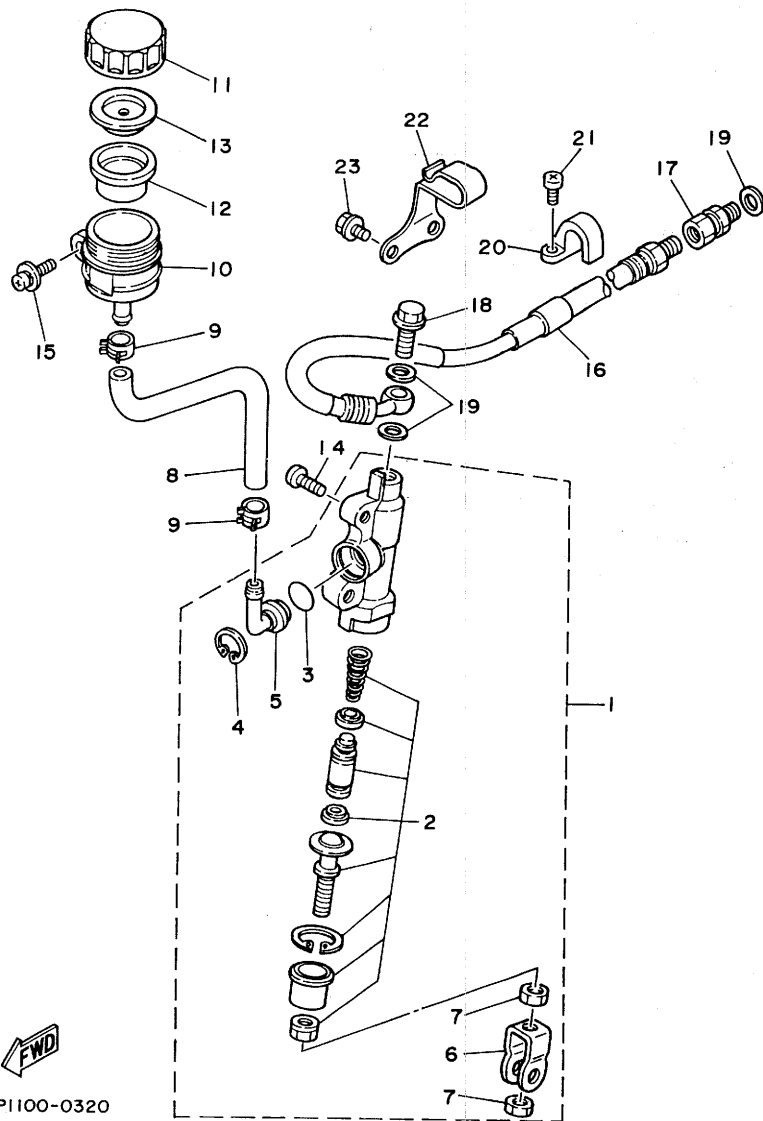

3SPI100-0320

REF. NO.	PART NO.	DESCRIPTION	Q'TY	REMARKS
1	3SP-2583V-00	RR. MASTER CYLINDER ASSY	1	
2	1FK-W0042-50	.CYLINDER KIT, master	1	
3	93210-15620	.O-RING	1	
4	2VN-25866-00	.CIRCLIP	1	
5	2VN-2582A-50	.JOINT	1	
6	3SP-27222-00	.JOINT	1	
7	95303-08600	.NUT	2	
8	3JD-25895-00	HOSE, reservoir	1	
9	90467-11044	CLIP	2	
10	2VN-25894-00	TANK, reservoir	1	
11	2VN-25852-50	CAP, reservoir	1	
12	2VN-25854-00	DIAPHRAGM, reservoir	1	
13	2VN-25855-00	BUSH, diaphragm	1	
14	92013-06016	BOLT	2	
15	90159-06056	SCREW, with washer	1	
16	3SP-25873-00	HOSE, brake 2	1	
17	3LC-25885-00	JOINT	1	
18	90401-10034	BOLT, union	1	
19	90201-10118	WASHER, plate	3	
20	2VM-25876-00	HOLDER, brake hose 2	1	
21	98580-05010	SCREW, pan head	2	
22	90462-12195	CLAMP	1	
23	95023-06008	BOLT	2	

E3

FIG. 33 GENERATOR

REF. NO.	PART NO.	DESCRIPTION	Q'TY	REMARKS
1	3SR-85510-10	STATOR ASSY	1	
2	3SR-85550-10	ROTOR ASSY	1	
3	92501-06014	SCREW, pan head	2	
4	92901-06600	WASHER, plate	2	
5	95311-10600	NUT	1	
6	90201-10774	WASHER, plate	1	

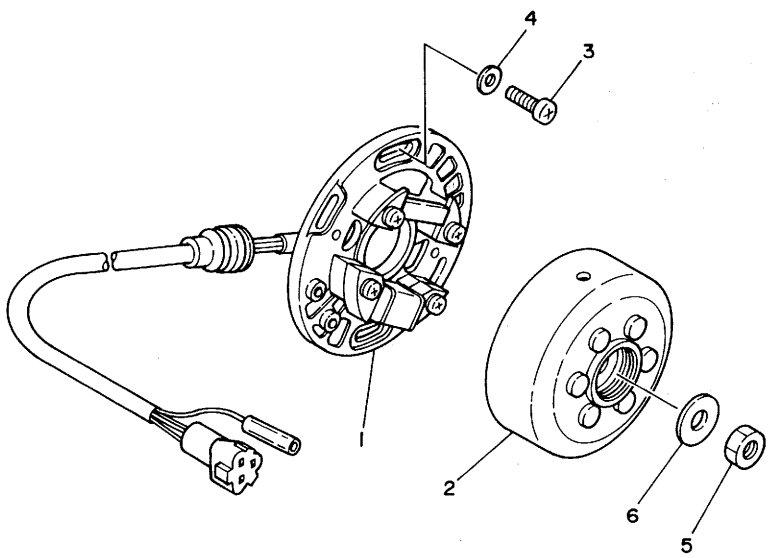

3SR2100-0330

E4

FIG. 34 HANDLE SWITCH. LEVER

REF. NO.	PART NO.	DESCRIPTION	Q'TY	REMARKS
1	38V-82911-00	HOLDER, lever 1	1	
2	38V-82913-00	HOLDER, lever lower 1	1	
3	23X-83912-00	LEVER 1	1	
4	90109-06799	BOLT	1	
5	95616-06100	NUT, u	1	
6	97006-05016	BOLT	2	
7	3SP-83922-00	LEVER 2	1	
8	90109-06577	BOLT	1	
9	95616-06100	NUT, u	1	
10	90149-06289	SCREW	1	
11	90170-06010	NUT	1	
12	23X-83976-00	SWITCH, handle 1	1	
13	437-83936-01	BAND, switch cord	2	

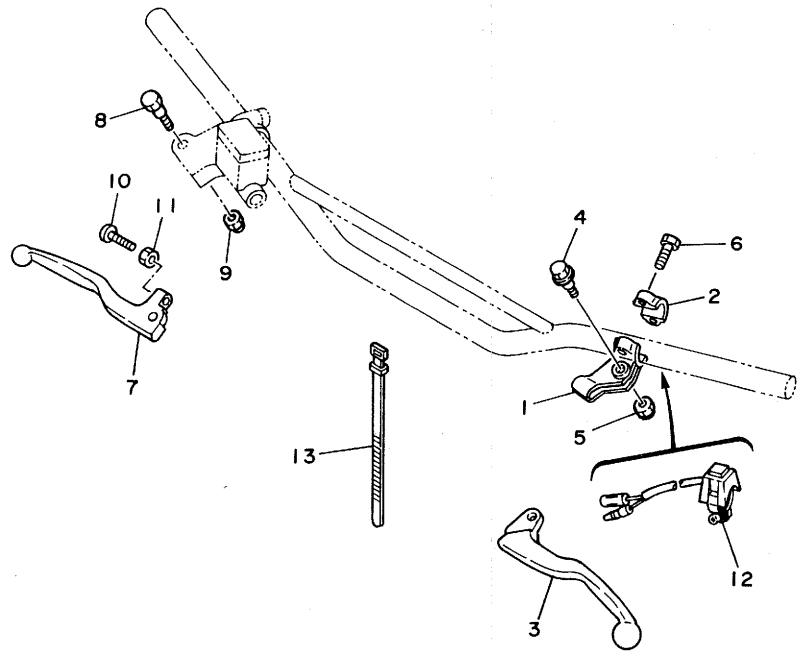

3SP1100-0340

E5

FIG. 35 ELECTRICAL 1

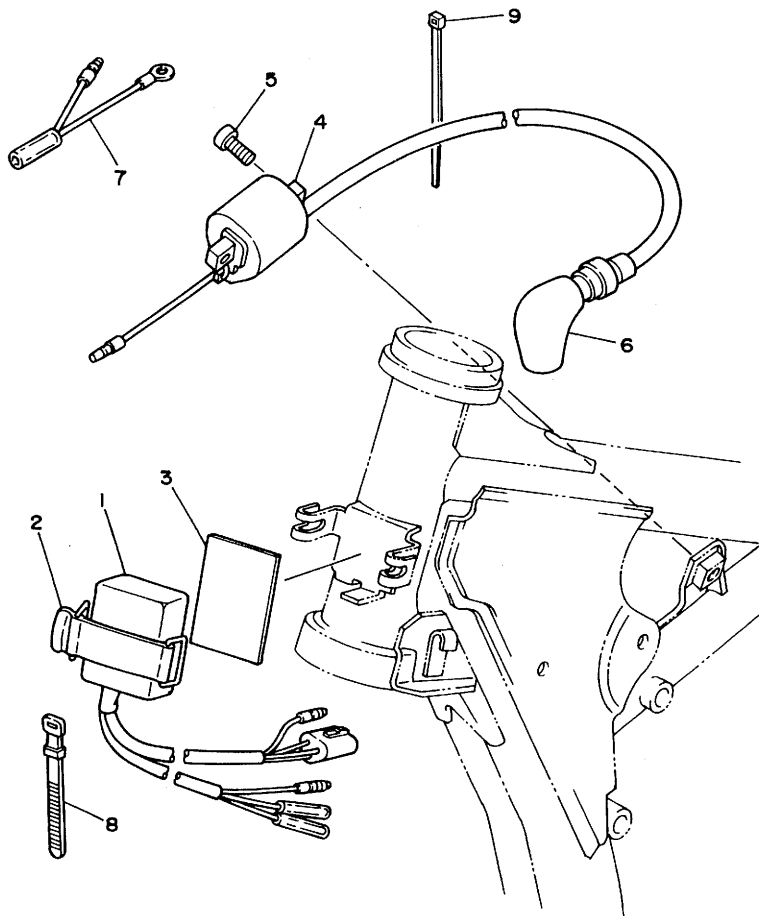

REF. NO.	PART NO.	DESCRIPTION	Q'TY	REMARKS
1	3SR-85540-10	C.D.I. UNIT ASSY	1	
2	21V-21376-00	BAND, tool	1	
3	2K7-85547-00	DAMPER	1	
4	3SR-82310-10	IGNITION COIL ASSY	1	
5	92502-06016	SCREW, pan head	2	
6	3R0-82370-20	PLUG CAP ASSY	1	UR
	2TV-82370-00	PLUG CAP ASSY	1	UR WITH NOISE SUPPRESSOR
7	5X1-82519-01	WIRE, earth lead	1	
8	25G-83936-00	BAND, switch cord	1	
9	12R-82591-00	BAND	1	



3SR2100-0350

E6

ALTERNATE PARTS

FIG. 36 ALTERNATE 1 (CHASSIS)

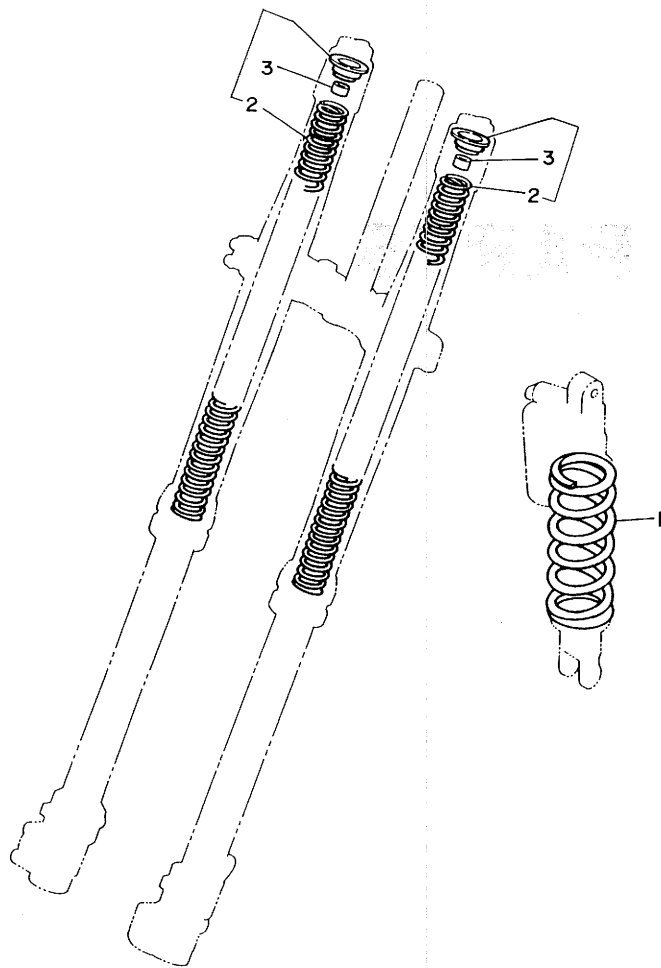

REF. NO.	PART NO.	DESCRIPTION	Q'TY	REMARKS
1	3JD-22212-01	SPRING (K=4.6)	1	AP (SOFT)
	3JD-22212-11	SPRING (K=4.8)	1	AP (SOFT) FOR EUROPE
	3JD-22212-21	SPRING (K=5.0)	1	AP (HARD)
	3JD-22212-31	SPRING (K=5.2)	1	AP (HARD) FOR EUROPE
2	3SP-23141-10	SPRING, front fork (K=3.50)	1	AP } WITH SET (SOFT)
	3SP-23143-L0	SEAT, spring lower	1	AP }
	3JD-23141-30	SPRING, front fork (K=0.380)	1	AP } WITH SET (HARD)
	3SR-23143-L0	SEAT, spring lower	1	AP }
3	3SP-23364-L0	COLLAR 2	1	UN



3SR2100-0360

E7

REPAIR KIT

FIG. 37 REPAIR KIT

REF. NO.	PART NO.	DESCRIPTION	Q'TY	REMARKS
1	3SR-11630-00	PISTON ASSY (STD)	1	AP
2	3SR-11631-00-94	.PISTON (STD)	1	
3	5X4-11611-00	.RING, piston (STD)	1	
4	137-11633-00	.PIN, piston	1	
5	3MA-11634-00	.CLIP, piston pin	2	
6	3JD-11650-00	CONNECTING ROD ASSY	1	AP
7	2HG-11651-00	.ROD, connecting	1	
8	3JD-11681-00	.PIN, crank 1	1	
9	90209-22257	.WASHER	2	
10	93310-522M4	.BEARING, cylindrical	1	
11	93310-216L2	.BEARING, cylindrical	1	

E8

INDEX

NUMERICAL INDEX

PART NO.	GRID NO.	PART NO.	GRID NO.	PART NO.	GRID NO.	PART NO.	GRID NO.	PART NO.	GRID NO.	PART NO.	GRID NO.
3SP-W0041-00	D-15	3JD-11992-10	B- 3	137-14143-50-AO	B-11	11X-15451-01	B-15	11X-21419-00	C- 9	3SP-23103-MO	D- 5
1FK-W0042-50	E- 3	3JD-11993-00	B- 3	137-14143-52	B-11	11X-15451-11	B-15	11X-21425-00	C- 9	3SR-23103-L0	D- 5
3SP-W0045-00	D-10	3JD-11993-10	B- 3	137-14143-54	B-11	11X-15462-00	B-15	5X6-21511-11	C-11	3SP-23110-L0	D- 5
3SP-W0046-00	D-13	11X-11995-01	B- 3	137-14143-56-AO	B-11	11X-15462-10	B-15	11X-21611-00	C-11	3SP-23111-L0	D- 4
3JD-W0047-00	D-10	11X-1240A-00	B- 7	137-14143-58-A1	B-11	3JD-15463-00	B-15	39X-21642-00	C-11		D- 5
3JD-W0047-50	D-13	3JD-1240A-00	B- 7	137-14143-60-AO	B-11	3JD-15463-10	B-15	3JD-21711-00	C-12	3SP-23113-L0	D- 4
1UY-W0048-50	D-10	2VN-12422-01	B- 6	137-14143-62	B-11	11X-15618-00	C- 2	3SP-2172A-00	C-12		D- 5
	D-13	11X-12428-00	B- 6	137-14143-64	B-11	11X-15620-01	C- 2	3SR-2172F-00	C-12	3JD-2312G-L0	D- 5
	D-10	11X-12428-10	B- 6	137-14143-66	B-11	11X-15621-01	C- 2	2VM-2172K-00	C-12		D- 6
3JD-W0057-00	D-13	11X-12450-00	B- 6	3JD-14147-00	B-10	11X-15641-00	C- 2	2VM-21721-00	C-12	3SP-23120-L0	D- 4
3JE-W1132-00	B- 2	3JD-12459-00	B- 6	3JE-14147-00	B-10	11X-15651-00	C- 2	3SR-21731-00	C-12	3JD-23125-L0	D- 4
3SP-W1441-00	B- 8	22W-12462-00	B- 7	3JE-14171-00	B-10	11X-15660-00	C- 2	3JD-2174F-00	C-12		D- 5
2VN-Y113F-00	B- 2	24X-12469-00	B- 7	3JD-14185-00	B-10	3SR-16111-00	C- 3	2VM-21741-00	C-12	3SP-23136-L0	D- 4
3SR-11111-00	B- 2	3JD-12476-00	B- 7	3JE-14185-00	B-10	3JD-16150-00	C- 3	22W-21791-00	C-13		D- 5
3SR-1131A-00	B- 2	1LU-1248A-01	B- 7	353-14186-00	B-10	3JD-16321-00	C- 3	3SP-22110-00	C-14	3SP-2314A-L0	D- 4
5X4-1131N-00	B- 2	3JD-12481-01	B- 7	363-14187-00	B-10	24X-16324-00	C- 3	156-22127-00	C-14		D- 5
5X4-1131N-10	B- 2	3JD-12482-00	B- 7	3JD-14194-00	B-10	3JD-16331-00	C- 3	3JD-22128-00	C-14	3SP-2314E-L0	D- 6
3SR-11311-00	B- 2	3JD-12483-00	B- 7	2HH-14197-00	B-10	3JD-16340-00	C- 3	3R4-22129-00	C-14	3SP-2314F-L0	D- 6
11X-11351-00	B- 2	3JD-12485-00	B- 7	278-14197-00	B-10	3JD-16351-00	C- 3	11X-22141-00	C-14	3SP-2314G-L0	D- 6
11X-11351-10	B- 2	353-13115-01	B-14	3SP-1441A-00	B- 9	4H7-16356-01	C- 3	3JD-22147-00	C-14	3SP-2314H-L0	D- 6
3SR-11400-00	B- 5	3SR-13565-00	B- 8	3JD-14451-00	B- 8	3JD-16371-00	C- 3	3JD-22151-00	C-14	3SP-2314J-L0	D- 6
3SR-11412-00	B- 5	2VN-13610-00	B- 8	3JD-14453-00	B- 8	3JD-16382-00	C- 3	3JD-22156-00	C-14	3JD-23141-MO	D- 4
3SR-11422-00	B- 5	1RX-13613-00	B- 8	39K-14457-00	B- 8	3JD-16383-00	C- 3	3JD-2217A-00	C-14		D- 6
5X4-11611-00	B- 5	2VN-13616-00	B- 8	3JD-14458-00	B- 8	3SR-17121-00	C- 5	3JD-2217F-00	C-15	3JD-23141-30	E- 7
	E- 8	2K7-13621-10	B- 8	3JD-14459-00	B- 8	3SR-17131-00	C- 5	3JD-22178-00	C- 9	3SP-23141-10	E- 7
	E- 8	80L-13621-01	B- 8	3SP-14461-00	B- 8	3JD-17151-00	C- 5	3JD-22178-10	C- 9	3SP-23142-L0	D- 4
3SR-11630-00	E- 8	3SR-14101-00	B-10	3JD-14462-00	B- 8	3JD-17161-00	C- 5	3JD-22199-00	C-14		D- 5
3SR-11631-00-94	B- 5	3SR-14101-10	B-10	3JD-14477-00	B- 8	11X-17211-00	C- 5	3SR-22201-00	D- 2	3SP-23143-L0	E- 7
	E- 8	3SR-14101-20	B-10	3JE-14561-00	B-10	3SR-17221-00	C- 5	3SR-22201-10	D- 2	3SR-23143-L0	D- 4
3SR-11631-00-95	B- 5	3JD-14103-00	B-12	3SR-14610-00	B-13	3SR-17231-00	C- 5	3SR-22210-00	D- 2		D- 6
137-11633-00	E- 8	3JD-14104-00	B-12	3R3-14613-00	B-13	11X-17241-00	C- 5	3SR-22210-10	D- 2		E- 7
	E- 8	3JD-14107-35	B-11	3M7-14615-00	B-13	3JD-17251-00	C- 5	3JD-22212-01	E- 7	3SP-23144-L0	D- 4
3MA-11634-00	E- 8	3JD-14112-45	B-11	3JD-1469A-01	B-13	3JD-17261-00	C- 5	3JD-22212-11	E- 7		D- 5
3JD-11650-00	E- 8	3JD-14112-50	B-11	39X-14747-00	B-13	3JD-17411-00	C- 5	3JD-22212-21	D- 2	3SP-23145-L0	D- 4
2HG-11651-00	B- 5	3JD-14112-55	B-11	3JD-14753-01	B-13	137-17417-00-05	C- 2		E- 7		D- 5
	E- 8	3JD-14112-60	B-11	565-14771-00	B-13	3JD-17421-00	C- 5	3JD-22212-31	E- 7	3SR-23146-MO	D- 5
3JD-11681-00	E- 8	3JD-14115-00	B-10		B-13	11X-18101-02	C- 8	3JD-22212-61	D- 2		D- 6
	B- 4	3JD-14116-A1	B-10	256-14919-00	B-10	11X-18110-01	C- 8	3SP-22213-00	D- 2	36Y-23146-10	D- 4
5X5-11911-01	B- 4	3JD-14116-A2	B-10	11X-15111-12	B-14	3R4-18140-00	C- 7	3JD-22214-00	D- 2		D- 5
5X5-11912-01	B- 4	3JD-14116-A3	B-10	11X-15121-11	B-14	3JD-18511-01	C- 7	3JD-22216-00	D- 2	3JD-23147-L0	D- 4
47X-11915-00	B- 3	3JD-14116-A4	B-10	3R3-15128-01	B-14	2VN-18512-01	C- 7	3JD-22224-00	D- 2		D- 5
5X4-11921-02	B- 4	3JD-14116-A5	B-10	1G8-15362-00	B-15	11X-18513-01	C- 7	3SP-22234-00	D- 2	3JD-23147-MO	D- 4
5X4-11922-00	B- 4	214-14118-00	B-10	11X-15383-00	C- 5	11X-18531-00	C- 7	3SP-22241-00	D- 2		D- 5
3JE-11931-00	B- 2	3JD-14131-00	B-10	2K7-15383-00	C- 5	11X-18535-00	C- 7	3JD-22253-00	D- 2	3SP-23147-L0	D- 4
3JE-11937-00	B- 4	193-14142-17	B-11	2VN-15411-00	B-15	11X-18540-00	C- 7	43M-22274-00	D- 2		D- 5
5X4-11952-00	B- 4	193-14142-20	B-10	3JD-15415-01	B-15	3SR-21110-00-UJ	C- 9	3JD-22475-00	D- 2	3SP-23147-MO	D- 4
3JD-11953-00	B- 4	193-14142-25-AO	B-11	3SR-15421-00	B-15	3JD-21123-01-UJ	C- 9	3SR-23102-L0	D- 4		D- 5
3SR-11990-00	B- 4	193-14142-30-AO	B-11	3JD-15431-00	B-15	21V-21376-00	E- 6	3SR-23102-MO	D- 4	3SP-23153-L0	D- 4
3JD-11992-00	B- 3										

NUMERICAL INDEX

PART NO.	GRID NO.	PART NO.	GRID NO.	PART NO.	GRID NO.	PART NO.	GRID NO.	PART NO.	GRID NO.	PART NO.	GRID NO.
3SP-23153-L0	D- 5	4A0-24380-00	D- 7	3SP-25870-00	D-15	3SR-85550-10	E- 4	90185-18104	D-12	90209-22257	E- 8
26H-23156-00	D- 4	3JD-24500-00	D- 7	3SP-25872-00	D-15	90101-08461	C- 9	90201-057H5	B- 4	90215-14224	C- 3
	D- 5	4X8-24512-00	D- 7	3SP-25873-00	E- 3	90101-08699	D-12	90201-06060	C- 2	90215-20261	C- 6
3JD-23158-L0	D- 4	4X8-24534-00	D- 7	2VM-25876-00	E- 3	90105-06553	C-11	90201-06570	B- 7	90240-08120	E- 2
	D- 5	5X7-24611-01	D- 7	3LC-25885-00	D-15	90109-063F7	C- 7		B- 7	90240-10117	E- 2
3SR-2316A-L0	D- 4	5X7-24612-00	D- 7		E- 3	90109-06418	C- 3	90201-06571	C-11	90269-11042	B- 8
	D- 5	509-24724-00	D- 8	2VN-25894-00	E- 3	90109-06551	B-13		C-11	90280-03045	B- 5
3SR-2316A-M0	D- 4	3JD-24731-10	D- 8	3JD-25895-00	E- 3	90109-06577	E- 5		C-12	90282-05038	B- 5
	D- 5	1LX-24738-01	D- 8	3JD-25919-00	D-10	90109-06799	E- 5		C-12	90338-10150	C-14
3SP-23166-L0	D- 4	107-24741-00	D- 8	3SP-25919-51	D-13	90109-08386	C- 9		D- 3	90340-12059	B-14
	D- 5	5X6-24748-10	D- 8	3SP-25920-00	D-13	90109-08512	B-13	90201-080E2	C- 9	90380-15104	B- 4
4V2-23167-L0	D- 6	3JD-24770-10	D- 8	3SP-25924-51	D-13	90109-08792	D-11	90201-08085	B- 8	90380-16056	C-14
3SP-23170-L0	D- 4	3SP-24770-00	D- 8	3GD-25933-00	D-10	90109-107E9	D- 2	90201-08087	B- 2	90381-08002	B- 6
	D- 5	3SP-24771-00	D- 8	3SP-26111-00	D-14	90109-142F4	C-15	90201-081A6	C- 9	90387-061F9	C-12
3JD-23171-L0	D- 4	1LX-25104-00	D- 9	1LX-26241-01	D-14	90116-08388	B- 2		C- 9	90387-06681	C-11
	D- 5	3SP-25111-00	D- 9	1LX-26242-01	D-14	90116-08392	B- 2		D-11	90387-07392	B- 7
24M-23184-00	D- 2	322-25118-00	D- 9	23X-26243-00	D-14	90116-08394	B- 2	90201-084K3	C- 9	90387-07573	B- 7
4V4-23194-L0	D- 6	55U-25181-01	D- 9	5X2-2628H-01	D-14	90116-08533	B- 2	90201-085E6	C- 9	90387-081A3	B-13
3JD-23340-L0	D- 6	3JD-25304-00	D-11	23X-26281-00	D-14	90119-05193	C-12	90201-085I2	B- 6	90387-086N4	C- 9
3SP-23346-L0	D- 6	3SP-25311-00	D-11	431-26282-01-98	D-14		C-12	90201-086I2	B-13	90387-087K5	C- 9
3SP-23356-L0	D- 6	3JD-25317-00	D-11	3JD-26311-00	D-14	90119-06063	C-11	90201-08759	C-15	90387-102V0	C-15
3SP-23357-L0	D- 4	4V4-25367-00	D-12	3JD-26335-00	D-14	90119-06185	B- 9	90201-08784	B- 6	90387-102W0	B- 2
	D- 6	3JD-25381-01	D-12	56A-26372-00	D-15	90119-06192	C-12	90201-10118	D-15	90387-151V9	D- 9
3SP-23364-L0	D- 5	3SP-25388-00	D-11	3JD-27200-01	E- 2		C-12		E- 3	90387-152F2	B- 4
	D- 6	2X3-25394-00	D-11	3JD-27217-00	E- 2	90122-06030	B- 8	90201-10119	C- 3	90387-152V1	D- 9
	E- 7	5X2-25394-00	D- 9	3SP-27222-00	E- 3	90123-08090	D-14		D-14	90387-164N2	C-14
3JD-23389-01	D- 6	39W-25444-01	D-11	3SP-27300-00	E- 2	90149-06011	D- 7	90201-106F2	C-15	90387-164N3	C-14
3SP-23393-L0	D- 4	39W-25445-01	D-11	3SP-27411-00	E- 2	90149-06272	D-10	90201-10774	E- 4	90387-167R5	C-15
	D- 5	39W-25446-01	D-11	3SP-27421-00	E- 2		D-13	90201-12474	C- 3	90387-16781	B-14
5Y3-23393-00	D- 6	39W-25448-00	D-11	3JD-27491-00	D-13	90149-06289	E- 5	90201-14740	C-15	90387-202A0	C- 6
2HG-23416-00	D- 3	2HH-25449-00	D-11	56A-28166-00	C-10	90152-06010	C- 2	90201-150H2	C- 3	90387-203V0	D-11
3SP-23418-00	D- 3	39W-25450-00	D-11	3SR-82310-10	E- 6	90159-05172	C-12	90201-154E9	B- 4	90401-10034	D-15
3SR-23435-01	D- 3	3JD-25451-01	D-11	2TV-82370-00	E- 6	90159-06016	C- 3	90201-15701	C- 5		E- 3
3SP-23441-00	D- 3	39W-25452-01	D-11	3R0-82370-20	E- 6	90159-06056	E- 3	90201-164H4	C-14	90430-06014	C- 3
3SR-23442-00	D- 3	3SP-2580T-00	D-10	5X1-82519-01	E- 6	90159-06146	B-15		C-15	90430-06016	B-15
5X6-23485-11	D- 3	3SP-2580W-00	D-13	688-82535-00	D-14	90170-06010	E- 5	90201-171G4	C- 2	90430-06166	B- 6
3JD-24110-00	D- 7	2VN-2582A-50	E- 3	12R-82591-00	C- 9	90170-14171	C- 3	90201-174E1	C- 3	90430-12038	B-14
5X6-2412F-00	D- 7	3SP-2582T-00	D-10		E- 6	90170-36394	D- 3	90201-174F7	C- 3	90430-12207	B-14
24X-24144-00	D- 7	3JD-2582W-00	D-13	38V-82911-00	E- 5	90176-08026	B- 2	90201-22555	C- 5	90445-08376	B-14
3SP-24173-00	D- 7	3GD-25827-00	D-13	38V-82913-00	E- 5	90179-08401	D-14		C- 5	90445-09058	D- 7
1LX-24181-00	D- 7	3SP-2583V-00	E- 3	23X-83912-00	E- 5	90179-08491	B- 2	90201-34683	C- 7	90445-09100	D- 7
22W-24181-00	C-12	2VN-25852-00	D-15	3SP-83922-00	E- 5	90179-10544	C-14	90201-365M5	D- 3	90445-11452	D- 7
	C-12	2VN-25852-50	E- 3	25G-83936-00	E- 6	90179-12373	C- 3	90202-06010	D- 7	90445-162A0	E- 2
3SR-24181-00	C-12	2VN-25854-00	E- 3	437-83936-01	E- 5	90179-16226	C- 6	90202-08022	C- 9	90446-09013	B- 7
3JD-24186-00	D- 7	56A-25854-00	D-15	23X-83976-00	E- 5	90179-28602	D- 3	90209-06096	B- 8	90450-15041	B- 7
3JD-24244-01	C-12	2VN-25855-00	E- 3	3SR-85510-10	E- 4	90179-28603	D- 3	90209-06290	B-14	90450-17036	B- 7
3JD-24245-01	C-12	2VN-25866-00	E- 3	3SR-85540-10	E- 6	90185-14070	C-15	90209-18135	C- 5	90450-22017	B- 7
3JD-24254-01	C-12	56A-25867-00	D-15	2K7-85547-00	E- 6	90185-16127	C-14	90209-22257	B- 5	90450-28014	B- 7

NUMERICAL INDEX

PART NO.	GRID NO.	PART NO.	GRID NO.	PART NO.	GRID NO.	PART NO.	GRID NO.	PART NO.	GRID NO.	PART NO.	GRID NO.
90460-51109	B- 8	91401-25020	D- 3	93210-09192	B- 2	9383A-14054	C- 6	95023-08035	D- 3		
90460-68230	B- 8	92011-06012	D-13	93210-14104	B-15	94108-215H9	D- 9	95023-08050	C-13		
90462-12195	E- 3	92011-08070	C- 9	93210-15151	C- 2	94108-216U5	D- 9		D- 3		
90465-08336	B-14		C- 9	93210-15620	E- 3	94108-219U5	D- 9	95026-06025	D-15		
90465-13154	D-14	92013-06016	E- 3	93210-27244	B- 2	94110-196W3	D-11	95303-08600	E- 3		
90467-09006	B- 7	92501-06012	D- 7	93210-45742	B-13	94110-196W6	D-11	95311-10600	E- 4		
90467-10008	D- 7		D- 8	93210-65721	B- 2	94110-199U4	D-11	95601-05100	B- 8		
90467-11044	E- 3	92501-06014	B-15	93211-07720	B- 2	94209-21229	D- 9	95601-08200	C- 9		
90468-15054	D- 7		E- 4	93300-60814	B- 4	94210-19222	D-11		C- 9		
90468-26048	C- 2	92501-06035	B-15		B- 6	94210-19224	D-11		C- 9		
90480-15064	B- 7	92501-08010	B-14	93300-60816	C- 9	94227-21123	D- 9		C- 9		
90480-18276	B- 7	92502-06016	E- 6		C- 9	94307-21145	D- 9	95611-08100	D-11		
90480-18354	D- 7	92701-06012	C- 5	93306-00418	D-11	94316-19156	D-11	95611-10200	D- 2		
90501-06162	D-15		C- 5	93306-00438	D-11	94327-19111	D-11	95611-12100	D- 3		
90501-12081	C- 2	92701-06035	C-14	93306-20209	D- 9	94330-21084	D- 9	95616-06100	E- 5		
90501-210F3	C- 3	92901-06200	D- 8	93306-30309	C- 5	94416-21453	D- 9		E- 5		
90501-240E7	B- 4	92901-06600	B-15	93306-30411	C- 5	94418-19485	D-11	95701-08500	C-13		
90504-03033	B- 8		E- 4	93306-37204	B- 5	94581-13116	D-12		D- 6		
90506-14453	E- 2	92901-08200	C-12	93310-216L2	B- 5	94681-13001	D-12		D-12		
90507-20030	B-13	92901-08600	D-10		E- 8	94702-00324	B- 2	97006-05016	E- 5		
90508-14767	C- 3		E- 2	93310-323T6	C- 3	94702-00325	B- 2	97021-05030	B- 4		
90508-14783	B- 4	92902-04100	B-10	93310-522B9	B- 5	95021-06060	B- 6	97021-06012	C- 2		
90508-26700	C- 2	92990-03100	B- 8	93310-522M4	E- 8	95021-08060	D- 6	97021-06025	C- 8		
90508-26731	C- 7		B-10	93311-31567	C- 5	95023-06008	B-13	97301-08040	D-10		
90508-28777	E- 2	92990-05100	B- 4	93311-41530	C- 5		B-15	98501-03008	B- 8		
90508-32535	C- 8	92990-05200	C-12	93315-10838	C- 4		E- 3		B-10		
90560-08213	B- 4	92990-06100	B- 8	93315-22046	C-14	95023-06010	C-11	98501-05012	B- 2		
90560-12280	C- 8		C-14	93315-31502	C- 4	95023-06012	B- 8	98501-05016	B- 3		
90560-15352	D- 9		D- 6	93317-22262	C-14		B-13		C-12		
90560-17279	C- 2		D- 7	93317-22263	C-14		B-13	98503-03008	D- 7		
90560-17335	C- 3	92990-08100	D-10	93332-00067	D- 3		C-12	98506-05008	B- 3		
90560-22281	D-14	92990-12200	D- 3	93332-00068	D- 3		C-12	98506-05016	D-14		
91001-06020	C-14	92990-18600	D-12	93340-21505	C- 3		D- 3	98511-04012	B-10		
91011-08040	C- 9	93102-15212	C- 3	93342-22208	C-14		D- 8	98580-05010	E- 3		
91011-08055	C- 9	93102-17263	C- 2	93399-99921	C-15	95023-06016	C-15	98706-04012	D-14		
91011-08095	C- 9	93102-20281	D- 9	93410-22039	C- 5	95023-06020	B- 7		D-15		
91011-10016	C-15	93102-22363	B- 5		C- 5		B- 8	98980-06020	D- 7		
91311-08025	D-13	93102-26042	C- 5	93440-15012	D- 2		C-12	99009-10400	C- 4		
91316-04006	B- 4	93103-10147	B- 6		C- 5		C-14	99080-07600	B- 6		
91316-05012	B-14	93103-32099	B- 5	93440-30113	C-15	95023-06025	B- 6	99510-10114	B- 2		
91316-06035	B-14	93104-08040	B- 4	93450-17129	B- 5		B-15		B- 2		
91316-06045	B-14	93104-16074	B- 2	93507-32031	C- 2	95023-06030	B- 7	99510-12016	B-14		
91316-06055	B-14	93104-18077	C-15	93521-64032	B- 4		B-15	99530-10014	B-15		
91316-06060	B-14	93106-22019	C-14	93603-14179	B- 4	95023-06035	B-15		B-15		
91316-06065	B-14	93106-28023	D-11	93603-22028	B- 6		D- 7				
91316-06070	B-14	93108-35004	C-14	93604-10011	B- 6	95023-06040	B-15				
91401-25015	E- 2	93109-12012	C- 8	9383A-12017	C- 6		B-15				
	E- 2	93109-20029	C-14	9383A-13031	C- 6	95023-08016	D- 8				